



SUBMERSIBLE PUMPS

# Instruction Manual



AL Series  
2 pole (3400rpm)  
Submersible  
Wastewater Pumps

CSA C22.2 No. 108-14 & UL778





Thank you for using HCP Submersible Pump.

# Contents

<b>1.General</b>	1
<b>2.Safety Information</b>	
2.1 Hazard Warning	2
2.2 Hazard Cautions	3
<b>3.Prior to Installation</b>	
3.1 Nameplate	4
3.2 Product Nomenclature	5
3.3 Model Detail	6
<b>4.Installation</b>	
4.1 Pump Mount	8
4.2 Piping	8
4.3 Protection	8
4.4 Electrical	9
4.5 Grounding	10
<b>5.Operation</b>	11
<b>6.Pump Protection Devices</b>	
6.1 Protector Type	12
<b>7.Maintenance</b>	
7.1 General Instruction	13
7.2 Maintenance Schedule routine	13
<b>8.Troubleshooting</b>	14
<b>9.Parts &amp; Drawing</b>	
9.1 1phase 50AL21.5	15
9.2 1phase 50AL22.2	16
9.3 1phase 80AL21.5	17
9.4 1phase 80AL22.2	18
9.5 3phase 50AL21.5	19
9.6 3phase 50AL22.2	20
9.7 3phase 80AL21.5 / 80AL22.2	21
9.8 3phase 80AL23.7A	22
9.9 3phase 80(100)AL25.5 / 80(100)AL27.5	23
9.10 3phase 80(100)AL211	24
<b>10.Wiring Diagram</b>	25
<b>11.Limited Warranty</b>	27

# 1

## General

- Carefully read through and fully understand the User's Instruction Manual before installation and operation.
- Keep User's Instruction Manual in proper and easy access place any time for pump install technician, operator and maintenance technician.
- When damage observed on the product, please contact with authorized local dealers or sales representative.
- Please pay close attention to the 'Warning' , 'Caution' and 'Note' parts of this 'Instruction Manual'.

**This is the safety alert symbol. Paying constant attention to safety is always extremely important.**



### **WARNING**

- **Risk of electrical shock** - Warning about hazards or unsafe practices which could result in severe personal injury or death.



### **CAUTION**

- **Risk of electrical shock** - Warning about hazards that will or can cause minor personal injury or product or property damage.

**This Company places heavy emphasis on product quality and safety, however, this Manual does not fully cover all safety matters. For this reason, the user or the maintenance person must pay special attention to their own safety as well.**

## 2

# Safety Information

## 2.1 Hazard Warning

### **WARNING**

#### **Risk of Electric Shock or unsafe practices which could result in severe personal injury or death.**

- Use Breaker and ensure the ground wire (Green) is properly grounded by a qualified electrician before operation to avoid the risk of fire or personal injury that may cause by power leakage in the event of motor failure.
- Do not lift, Carry or Hang the pump by the electrical cables. Damage to the electrical cable can cause Shock, Burn or death.
- Do not enter the pond during pump operation to avoid personal casualties in the event of leakage.
- Use an approved motor control that matches motor input full load amperes with thermal overload relay or adjusted in accordance with the control instructions.
- Use an approved liquid level control with correct rating that matches marked motor input in full load amperes or service factor amperes.
- Disconnect the power before servicing.
- The pump is designed for use with inflammable liquids and a non-hazardous environment.
- Do not strain, modify, or any excessive force to the power cable, it can damage the cable and cause short circuit and even lead to electrocution or fire.
- Do not install the pump into any location classified as hazardous environment.
- Do not use this pump in swimming pools or marine areas.

## 2.2 Hazard Cautions

### CAUTION

#### **Risk of Electric Shock that will or can cause minor personal injury, product or property damage.**

- To reduce the risk of electric shock, pull the plug before servicing on the pump.
- Inspect your pump for damage that may have occurred during shipment.
- Inspect the pump for any cracks, dents, or damage threads.
- Check power cord for any cuts or damage.
- If in a climate where the fluid in the casing could freeze, never leave liquid in the pump casing. Drain the casing complete. During winter months and cold weather, the liquid could freeze and damage the pump casing.
- DO NOT run the equipment dry or start the pump without the casing flooded.
- The pump shaft MUST turn clockwise when viewed from the motor end. It is absolutely essential that the rotation of the motor be checked before installation and starting the pumps. Incorrect rotation of the pump can unscrew the impeller nut and cause severe damage to pumping assembly.
- The applicable pumping liquid temperature should be 32-104 °F (0-40 °C), and the pump may be damaged if exceeding such range.
- The pH value of liquid for the operation should be between 5~9.
- Power supply voltage tolerance is within  $\pm 10\%$  of the rated voltage.
- Vent sewage and septic tank according to local requirements or standards.
- Check proper oil level in seal chamber periodically. Check for water in the seal housing periodically.
- A three-phase cord-connected or a single-phase cord connected sewage, effluent, and grinder submersible pump, must have a motor control and liquid level control provided at time of installation. The control device should have suitable voltage, ampere, frequency, grounding and horsepower rating for the pump to which it is connected.
- Remove the oversized substance suspended in water before operating the pump to prevent clogging and inadequate water volume. Make sure that the size of the substance suspended in water is smaller than the solid passage of the pump. The substance must be able to go through the strainer and the impeller.

# 3

## Prior to Installation

- Check if the product, spare parts and accessories free from defect or damage.
- Check carefully all items correspond to the 'Nameplate' of the pump, including the model, output (motor horsepower), and voltage are all correct. Do not operate the pump if any of Nameplate information is not line with your specification.
- DO NOT operate this pump under any conditions or applications other than those which have been mentioned in this Instruction Manual.

### 3.1 Nameplate

- Every pump has its own 'Nameplate' (see Figure 1). Make sure the information including 'Model Name', 'Output' (horsepower), 'Voltage', 'Frequency', 'Phase' and, 'rpm' information are correct. Contact an authorized local dealer or HCP sales representative if you have any questions regarding the 'Nameplate'.

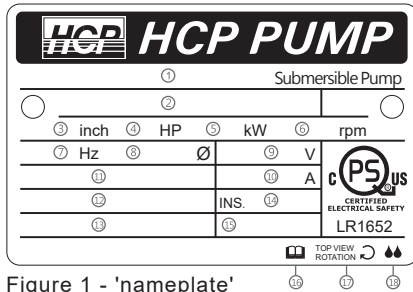

Figure 1 - 'nameplate'

1	Serial number / Date	10	Rated current
2	Model Name	11	Min. head
3	Discharge	12	Max. head
4	Rated output horsepower	13	Flow
5	Rated output kW	14	Insulation class
6	Rated rotation speed	15	Thermally Protected
7	Frequency	16	Read instruction manual
8	Phase	17	Direction of rotation
9	Rated Voltage	18	Watertight submersible pump

Note: Panel nameplate marked "For Panel only" is provided along with instruction manual. Please place the panel nameplate on the control panel without a plug or near the receptacle for the pump with a plug.

### 3.2 Product Nomenclature

80	AL	2	3.7	A		-	6	35	O	E	X
----	----	---	-----	---	--	---	---	----	---	---	---

**Pump Discharge**  
 Blank = 2inch (50mm), 25 = 25mm = (1inch), 32 = 32mm = (1.25inch), 50 = 50mm = (2inch), 80 = 80mm = (3inch), 80(100) = 80mm(100mm)= 3inch(4inch)

**Pump Series**  
 AL Series Submersible Wastewater

**Pole**  
 2=2 pole (3400rpm)

**Motor kW**  
 .4 = 0.4kW (0.5HP), .8 = 0.75kW (1HP), 1.0 = 1.0kW(1.3HP), 1.5 = 1.5kW (2HP), 2.2 = 2.2kW (3HP), 3.7 = 3.7kW (5HP), 4.5 = 4.5kW (6HP), 5.5 = 5.5kW (7.5HP), 7.5 = 7.5kW (10HP), 11 = 11kW (15HP)

**Version**  
 Blank(), A

**Float**  
 Blank(), F

**Frequency**  
 6 = 60Hz

**Phase/Voltage**  
 1A = 1phase 110v, 1B = 1phase 115v, 11 = 1phase 120v, 1C = 1phase 208v  
 1D = 1phase 220v, 1E = 1phase 230v, 12 = 1phase 240v, 3C = 3phase 208v  
 3D = 3phase 220v, 3E = 3phase 230v, 32 = 3phase 240v, 3F= 3phase 440v  
 3G = 3pahse 460v, 34 = 3phase 480v, 35 = 3phase 575v, 36 = 3phase 600v

**Cable code ( \* )**  
 7 = SJOW + US 3prong plug, L = SJOW Cable, O = SOW / SOOW Cable

**Cable length ( # )**  
 3 = 10ft, 5 = 15ft, 6 = 20ft, 8 = 25ft, E = 30ft, G = 50ft, H = 60ft,  
 J = 70ft, K = 80ft, L = 90ft, M = 100ft, X = 120ft, O = 150ft

**Protection**  
 P= Thermal protector, T = MTS (Motor Thermal Sensor), M = MS (Moisture Sensor)  
 S = MTS + MS, X = Without Thermal protector or Sensor

### 3.3 Model Detail

Model	Horse Power HP(kW)	Phase	Hz	Volts	FLA	Discharge Inch
50AL21.5-612 * # P	2 (1.5)	1	60	240	9.6	2
50AL21.5 F-612 * # P	2 (1.5)	1	60	240	9.6	2
50AL21.5-632 * # X	2 (1.5)	3	60	240	5.8	2
50AL21.5-634 * # X	2 (1.5)	3	60	480	2.9	2
50AL21.5-635 * # X	2 (1.5)	3	60	575	2.3	2
80AL21.5-612 * # P	2 (1.5)	1	60	240	9.6	3
80AL21.5 F-612 * # P	2 (1.5)	1	60	240	9.6	3
80AL21.5-632 * # X	2 (1.5)	3	60	240	5.8	3
80AL21.5-634 * # X	2 (1.5)	3	60	480	2.9	3
80AL21.5-635 * # X	2 (1.5)	3	60	575	2.3	3
50AL22.2-612 * # X	3 (2.2)	1	60	240	14.0	2
50AL22.2 F-612 * # X	3 (2.2)	1	60	240	14.0	2
50AL22.2-632 * # X	3 (2.2)	3	60	240	8.4	2
50AL22.2-634 * # X	3 (2.2)	3	60	480	4.2	2
50AL22.2-635 * # X	3 (2.2)	3	60	575	3.4	2
80AL22.2-612 * # X	3 (2.2)	1	60	240	14.0	3
80AL22.2 F-612 * # X	3 (2.2)	1	60	240	14.0	3
80AL22.2-634 * # X	3 (2.2)	3	60	480	4.2	3
80AL22.2-635 * # X	3 (2.2)	3	60	575	3.4	3
80AL23.7A-612 * # X	5 (3.7)	1	60	240	23.6	3
80AL23.7A-632 * # X	5 (3.7)	3	60	240	14.4	3
80AL23.7A-634 * # X	5 (3.7)	3	60	480	7.2	3
80AL23.7A-635 * # X	5 (3.7)	3	60	575	5.8	3

Remark:  
 Cable code ( \* ): 7 = SJOW + US 3prong plug, L = SJOW Cable, O = SOW / SOOW Cable  
 Cable length ( # ): 6 = 20ft, 8 = 25ft, E = 30ft, G = 50ft, H = 60ft, J = 70ft, K = 80ft, L = 90ft, M = 100ft, X = 120ft, O = 150ft

### 3.3 Model Detail

Model	Horse Power HP(kW)	Phase	Hz	Volts	FLA	Discharge Inch
80(100)AL25.5-632 * # X	7.5 (5.5)	3	60	240	20.4	3
80(100)AL25.5-634 * # X	7.5 (5.5)	3	60	480	10.2	3
80(100)AL25.5-635 * #	7.5 (5.5)	3	61	575	8.2	3
80(100)AL27.5-632 * #	10 (7.5)	3	62	240	27.0	3
80(100)AL27.5-634 * #	10 (7.5)	3	63	480	13.5	3
80(100)AL27.5-635 * #	10 (7.5)	3	64	575	10.8	3
80(100)AL211-634 * #	15 (11)	3	65	480	18.9	3
80(100)AL211-635 * #	15 (11)	3	66	575	15.1	3
Remark: Cable code ( * ): 7 = SJOW + US 3prong plug, L = SJOW Cable, O = SOW / SOOW Cable Cable length ( # ): 6 = 20ft, 8 = 25ft, E = 30ft, G = 50ft, H = 60ft, J = 70ft, K = 80ft, L = 90ft, M = 100ft, X = 120ft, O = 150ft						

# 4

## Installation

### 4.1 Pump Mount

- All pumps as a free-standing unit. Set the pump on the floor of the basin.
- Several series of pumps can be installed on the Guide Rail System for easier lift out for inspecting and servicing purposes. The Guide Rails allow removal of the pump without disturbing the piping or require personnel to enter the wet well. Contact the local dealer or HCP sales representative for the appropriate Guide Rail System.
- Install the Guide Rail on hard level surface such as cement, asphalt, etc. Never place the pump directly on earth, clay or gravel surfaces.

### 4.2 Piping

- All piping must be supported independently supported, accurately aligned, and be capable of handling semi-solids.
- Reduce the number of bends or turns in the discharge piping for maintaining smooth outlet flow.
- All pump models covered in this manual are designed to be used in a wet, flooded sump. Due to this intended service, no suction piping is required.
- The piping must not be smaller than pump discharge.
- Install a check valve to prevent pump damage caused by water hammer.

### 4.3 Protection

- Pump model equipped with Motor Thermal Sensor (MTS) – MTS (Normal: closed; abnormal: open) requires connect lead wires marked 2 & 2 with the control circuit or control relay to protect the motor from overheating and cause motor failure. Failure to connect MTS will void the warranty on the unit.
- Pump model equipped with Moisture Sensor (MS) – MS (Normal Open; abnormal Close) requires to be connected on the lead wires marked 1 & 1 to control the relay circuit, allowing the sensor to detect any moisture in mechanical seal chamber which may cause seals failure. To prevent water penetrates motor to causes electric leakage and burn the motor.
- Pump must install on a dedicated earth leakage circuit breaker and a thermal overload relay.

#### 4.4 Electrical



### **WARNING**

**Risk of Electric Shock - Electricity is dangerous. It can lead to burn, shock, or cause death. When installing, operating or servicing this pump, following the instruction below.**

- Use an approved motor control that matches motor input in full-load amperes with a thermal overload relay or adjust it according to the control instructions.
- DO NOT splice the power cord.
- DO NOT remove power supply cord and strain relief or connect conduit directly to the pump.
- DO NOT operate the pump and motor unless it is properly grounded. Wire the pump directly to a grounded terminal block in automatic float or pump control panel that is at least the size of the circuit conductors supplying the pump, and to the grounding screw provided within the wiring compartment. Be sure to follow all local electrical codes where the unit is installed.
- Make sure the supply frequency and voltage corresponds to the frequency and voltage requirements on the Nameplate. The supply voltage must be within 10% of the Nameplate voltage. Incorrect voltage can cause serious damage to the motor and could result in a fire, which would invalidate the warranty. If in doubt consult a licensed electrician.
- Pump must rotate in a clockwise direction (viewed from the motor end). Never operate pump and motor in reverse. If a three phase unit is running backwards, interchange two of the three power supply wires to reverse the motor's direction of rotation.
- Connect the pump to its own circuit with nothing else on the same circuit.
- Install the pump in accordance with the National Electrical Codes ANSI/NFPA 70. Install a fused disconnect switch or a circuit breaker.
- Pumps without Thermal protector must install on dedicated earth leakage circuit breaker and a thermal overload relay.
- Install only on a circuit protected by a Ground-Fault Circuit-Interrupted (GFCI) for pump cord with plug.
- Connect only to a properly grounded, grounded type receptacle.

#### 4.5 Grounding



### **WARNING**

#### **Risk of Electric Shock - during operation of this pump requires the provision of acceptable grounding:**

- When the means of connection to the supply-connection box is other than grounded metal conduit, ground the pump back to the service by connecting a copper conductor, at least the size of the circuit conductors supplying the pump, to the grounding screw provided within the wiring compartment.
- This pump is provided with a means for grounding. To reduce the risk of electric shock from contact with adjacent metal parts, bond supply box to the pump-motor-grounding means and to all metal parts accessible at the well head, including metal discharge pipes, metal well casing, and similar parts, by means of an equipment-grounding conductor at least the size of the well-cable conductors, or the equivalent, that runs down the well with the well cable and.
- For a cord and plug-connected pump, the word "WARNING" and the following instructions or the equivalent: "Risk of electric shock – This pump is supplied with a grounding conductor and grounding-type attachment plug. To reduce the risk of electric shock, be certain that it is connected only to a properly grounded, grounding-type receptacle."

## 5 Operation

### **⚠ DANGER**

**Do not operate this pump in areas where explosive or flammable materials are present. Serious personal injury, death, or major property damage will result.**

### **⚠ WARNING**

**Hazardous impellers and the possibility of unexpected starts, rotating the impeller with hands can cause loss of fingers. Disconnect the electrical power before working on or handling the pump for any reason.**

- It is absolutely essential that the rotation of the pump be checked.
- All the pumps covered in this manual turn a clockwise direction as viewed from the motor end.
- If the thermal overload frequently trips frequently, check for the cause. It could be impeller blockage, wrong / low voltage, or electrical failures in the motor.
- Pump must stop before the liquid level reach the pump's Lowest Water Level (L.W.L.)
- Pump operation is limited to 5 ~ 10 minutes at or below Continuous Water Level (C.W.L.)
- DO NOT allow the pump to run in a dry sump. It will void the warranty and may damage the pump.
- Install the pump in accordance with the National Electrical Codes. Use an with approved motor control that matches motor input full load amperes with a thermal overload relay or adjusted in accordance with the control instructions.
- Select the piping that fits to the flow capacity of the pump. Inappropriate piping (too large or too small) can result in excessive noise and vibration during the pump's operation.
- Make sure the check valve of the pipeline operate normally and check if the flow capacity is correct. Air might be gathering in the check valve if the pump is operating without discharging the water. The air has to be released if an air pocket is found at the check valve.

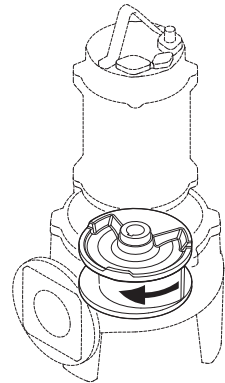

# 6

## Pump Protection Devices

### 6.1 Protector Type (Optional)

- Motor Thermal Sensor (MTS)

MTS embedded in each phase of the three-phase stator winding embedded sensor (Normal: closed; Abnormal :open). Note: MTS comes with 2 leads marked with "2" on the cable.

- Moisture Sensor (MS)

MS equipped in Mechanical Seal Lubricant chamber (Normal: open; Abnormal :close).

Note: MS comes with 2 leads marked with "1" on the cable.

### CAUTION

- When the sensor activates an alarm, stop using the pump immediately and call authorized dealer or HCP sales representative. The warranty is void if the pump damage is caused by failure to connect the protector or by continued operation after alarm activation.

# 7 Maintenance

Only qualified mechanics with proper tools and knowledge should attempt to service this pump.

## 7.1 General Instruction

### CAUTION

- Warning about hazards that will or can cause minor personal injury, product damage, or property damage.
- It must be very careful when disassembling and replacing new O-ring to assemble the motor and mechanical seal chamber. Improper assembly may impair the water resistance and cause motor burn by leakage, and it will void the warranty.

### WARNING

- Hazardous voltage can shock, burns, or kill. Disconnect the electrical power before attempting any service or work on pump.

## 7.2 Maintenance Schedule routine

Daily	1.Operating Current: within range of current rating. 2.Operating Voltage: within a safe range. ( $\pm 10\%$ of rated voltage) 3.Check the output flow rate for its normal value.
Monthly	Check the insulation, if it is lower than $20M\Omega$ (with a 500V megger),maintenance is recommended. Replace a new motor immediately when insulation is lower than $1M\Omega$ .
Annually	Inspect lubricant : Pumps should be checked every 6000 hours or 12 months (whichever comes first). <b>[Remarks]</b> Loosen the oil plug screw and check the color of the lubricant. If the lubricant looks unclear, please change the mechanical seal and the lubricant immediately. Apply adhesive before re-securing the oil plug screw to strengthen the screw against leakage. Oil specifications: VG32 or equivalent.
Every 2 to 5 years	1.Strongly recommended to overhaul or inspect the pump regularly even if it is still operating. This maintaining procedure can extend the pump's operating lifecycle. 2.Please contact your authorized local dealers or HCP for such service.

## 8

# Troubleshooting

## ⚠ WARNING

Hazardous voltage can shock, burns, or kill. Disconnect the electrical power before attempting any service or repair work on pump.

SYMPTOM	POSSIBLE CAUSE	RECOMMENDED SOLUTION
Pump Not Operating	Power failure	Check power and correct connection.
	Defective cable	Replace power cable.
	Impeller clogged	Remove the foreign objects from impeller or casing.
	Bad Motor Protector	Replace new motor protector.
	The motor burn out	Rewind or Replace new motor.
	Float switch defective	Replace new float switch.
Pump stop during operation	Bad Control Panel	Repair or replaced.
	Impeller Jammed	Remove the foreign objects from impeller or casing.
	Abnormal voltage	Check the power and make sure it corresponds to the nameplate.
Pump not reaching design Flow rate	The motor protector tripped	Make sure liquid temperature is below 40°C pump is complete submerged.
	Incorrect rotation	Reverse two of three leads on a three phase motor.
	Worn and damaged impeller or cavitation	Replace new impeller.
	The block of strainer	Remove the foreign objects from impeller or casing.
	Objects inside the pump or the impeller	Remove the foreign objects from impeller or casing.
	Valves and pipe plugged	Remove plugged objects or replace new valves or pipes.
	System head excessive	Consult dealer.
Electric Leakage Circuit Breaker Activated	Cavitations	Reposition liquid level control.
	Power cable damaged	Replace new cable.
	Wet cable terminal	Reconnect after drying out.
	Worn mechanical seal cause water enter	Replace new mechanical seals and oil seal.
Abnormal High Amperage	The motor burns	Replace new motor.
	Abnormal voltage	Check the power and make sure it corresponds to the nameplate.
	Incorrect rotation	Reverse two of three leads on a three-phase motor.
	High viscosity liquid	More liquid needs to be added to the pump fluid to decrease its viscosity.
	Objects inside the pump or the impeller	Remove the foreign objects from impeller or casing.
Defective bearings	Replace new bearing.	

# 9 Parts Drawing

## Single-Phase

1phase 50AL21.5

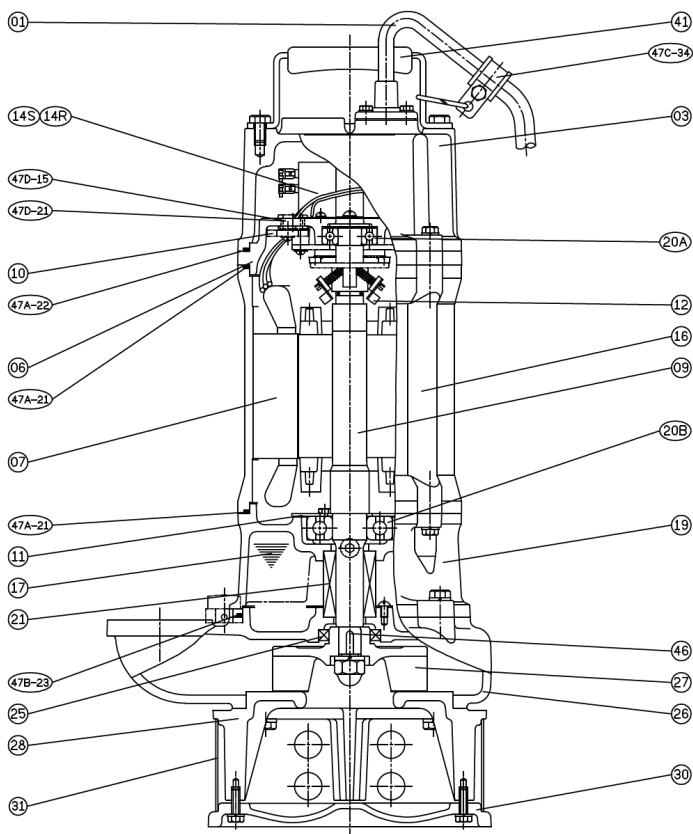

NO.	Part name	Material	QTY
01	Cable		1
03	Upper Cover	FC200	1
06	Bracket	FC200	1
07	Stator		1
09	Shaft End	SUS304	1
10	Auto-cut Protector		1
11	Bearing Fixer	SPCC	1
12	Centrifugal Switch		1
14R	Capacitor		1
14S	Start Capacitor		1
16	Motor Frame	FC200	1
17	Lubricant		
19	Bearing Bracket	FC200	1
20A	Bearing		1

NO.	Part name	Material	QTY
20B	Bearing		1
21	M. Seal	CA/CE & SIC/SIC	1
25	Oil Seal	NBR	1
26	Casing	FC200	1
27	Impeller	FC200	1
28	Casing Cover	FC200	1
30	Footing	FC200	1
31	Strainer	SUS304	1
41	Handle	SUS304+NBR	1
46	Impeller Key	SUS304	1
47	Gasket Kit		

# 9

# Parts Drawing

# Single-Phase

1phase 50AL22.2

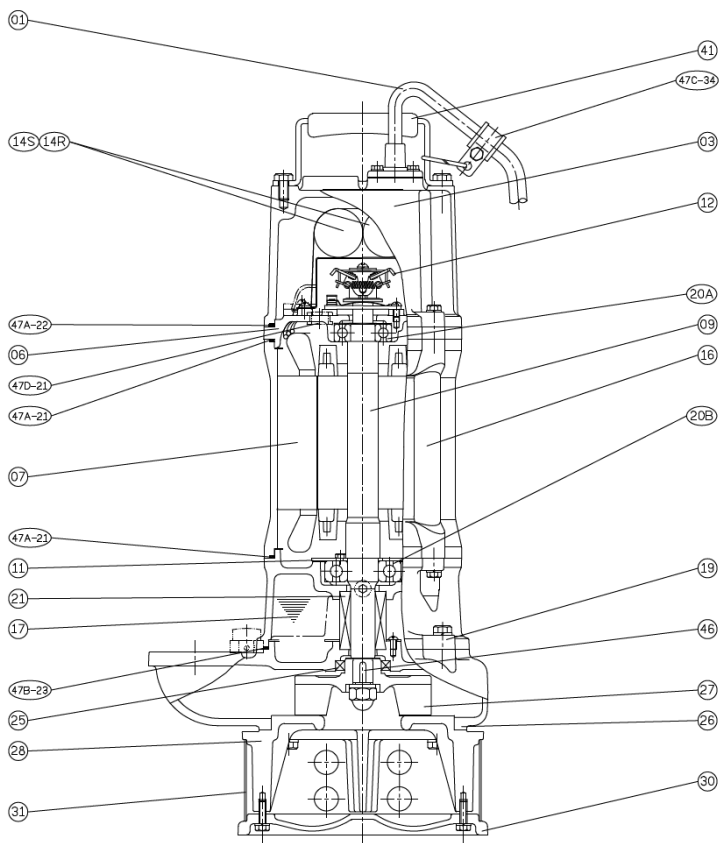

NO.	Part name	Material	QTY
01	Cable		1
03	Upper Cover	FC200	1
06	Bracket	FC200	1
07	Stator		1
09	Shaft End	SUS304	1
11	Bearing Fixer	SPCC	1
12	Centrifugal Switch		1
14R	Capacitor		1
14S	Start Capacitor		1
16	Motor Frame	FC200	1
17	Lubricant		
19	Bearing Bracket	FC200	1
20A	Bearing		1
20B	Bearing		1

NO.	Part name	Material	QTY
21	M. Seal	CA/CE & SiC/SiC	1
25	Oil Seal	NBR	1
26	Casing	FC200	1
27	Impeller	FC200	1
28	Casing Cover	FC200	1
30	Footing	FC200	1
31	Strainer	SUS304	1
41	Handle	SUS304+NBR	1
46	Impeller Key	SUS304	1
47	Gasket Kit		

# 9

# Parts Drawing

# Single-Phase

1phase 80AL21.5

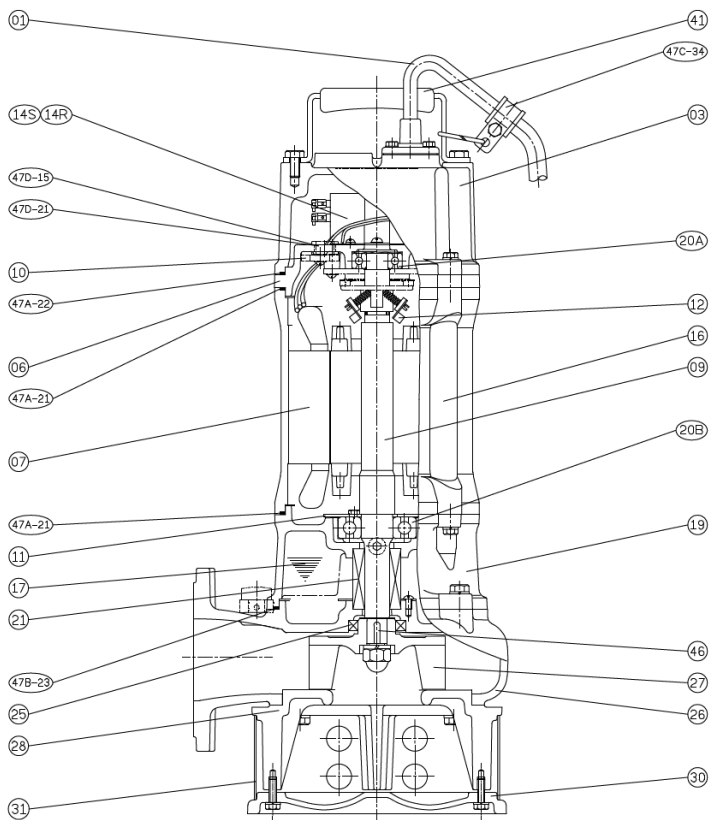

NO.	Part name	Material	QTY
01	Cable		1
03	Upper Cover	FC200	1
06	Bracket	FC200	1
07	Stator		1
09	Shaft End	SUS304	1
10	Auto-cut Protector		1
11	Bearing Fixer	SPCC	1
12	Centrifugal Switch		1
14R	Capacitor		1
14S	Start Capacitor		1
16	Motor Frame	FC200	1
17	Lubricant		
19	Bearing Bracket	FC200	1
20A	Bearing		1

NO.	Part name	Material	QTY
20B	Bearing		1
21	M. Seal	CA/CE & SiC/SiC	1
25	Oil Seal	NBR	1
26	Casing	FC200	1
27	Impeller	FC200	1
28	Casing Cover	FC200	1
30	Footing	FC200	1
31	Strainer	SUS304	1
41	Handle	SUS304+NBR	1
46	Impeller Key	SUS304	1
47	Gasket Kit		

# 9

## Parts Drawing

### Single-Phase

1phase 80AL22.2

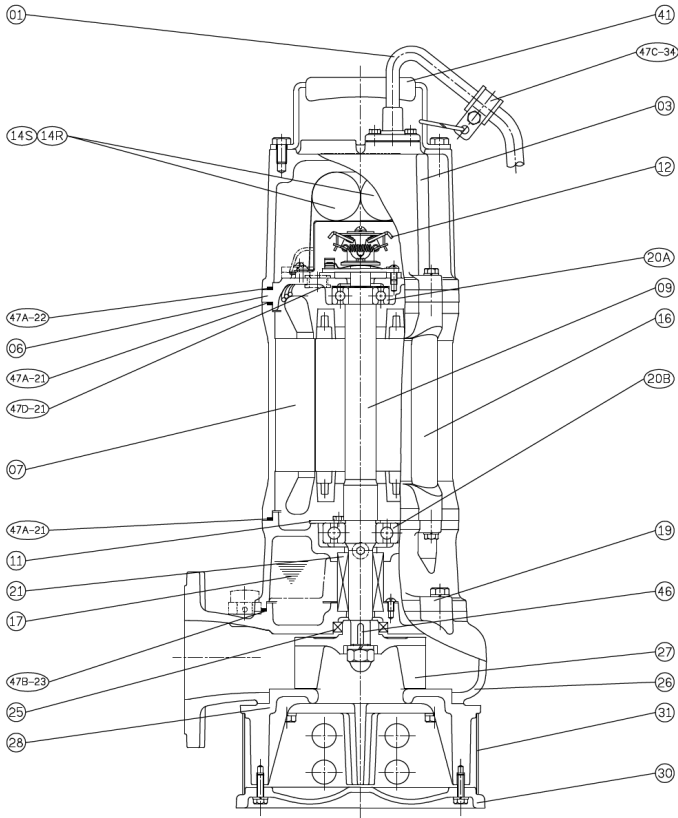

NO.	Part name	Material	QTY
01	Cable		1
03	Upper Cover	FC200	1
06	Bracket	FC200	1
07	Stator		1
09	Shaft End	SUS304	1
11	Bearing Fixer	SPCC	1
12	Centrifugal Switch		1
14R	Capacitor		1
14S	Start Capacitor		1
16	Motor Frame	FC200	1
17	Lubricant		
19	Bearing Bracket	FC200	1
<b>20R</b>	<b>Bearing</b>		<b>1</b>

NO.	Part name	Material	QTY
21	M. Seal	CA/CE & SIC/SIC	1
25	Oil Seal	NBR	1
26	Casing	FC200	1
27	Impeller	FC200	1
28	Casing Cover	FC200	1
30	Footing	FC200	1
31	Strainer	SUS304	1
41	Handle	SUS304+NBR	1
46	Impeller Key	SUS304	1
47	Gasket Kit		

# 9

# Parts Drawing

## Single-Phase

1phase 80AL23.7A

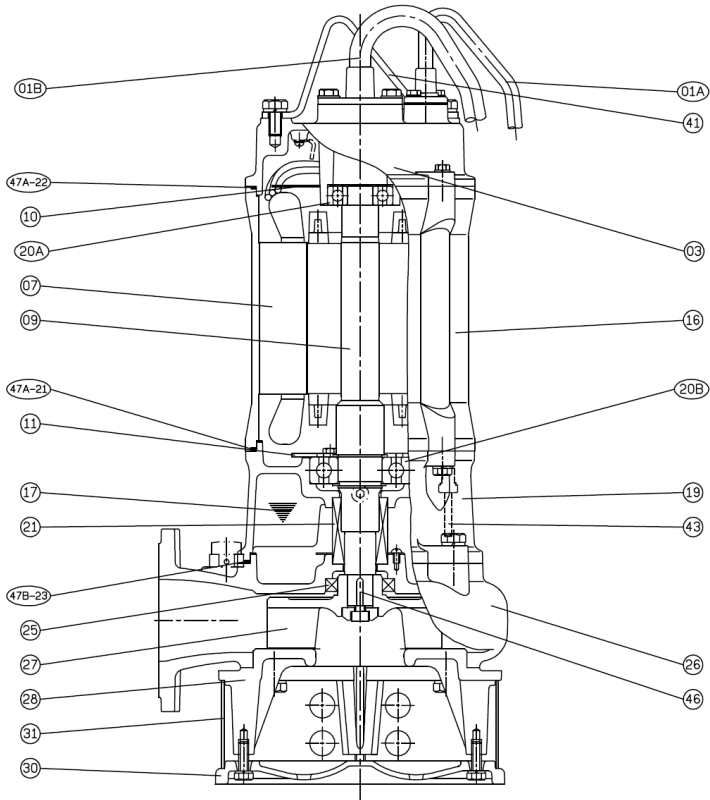

No.	Part name	Material	QTY	Remark
01A	Cable		1	
01B	Cable		1	
03	Upper Cover	FC200	1	
07	Stator		1	With MTS
09	Shaft End	SUS403	1	
10	Protective Plate		1	
11	Bearing Fixer	SPCC	1	
16	Motor Frame	FC200	1	
17	Lubricant			
19	Bearing Bracket	FC200	1	
20A	Bearing		1	
20B	Bearing		1	
21	M. Seal	CA/CE & SC/SIC	1	

No.	Part name	Material	QTY	Remark
25	Oil Seal	NBR	1	
26	Casing	FC200	1	
27	Impeller	FC200	1	
28	Casing Cover	FC200	1	
30	Footing	FC200	1	
31	Strainer	SUS304	1	
41	Handle	SUS304	1	
43	Moisture Sensor		1	
46	Impeller Key	SUS304	1	
47	Gasket Kit			



# 9

# Parts Drawing

# Three-Phase

3phase 80AL21.5 / 80AL22.2

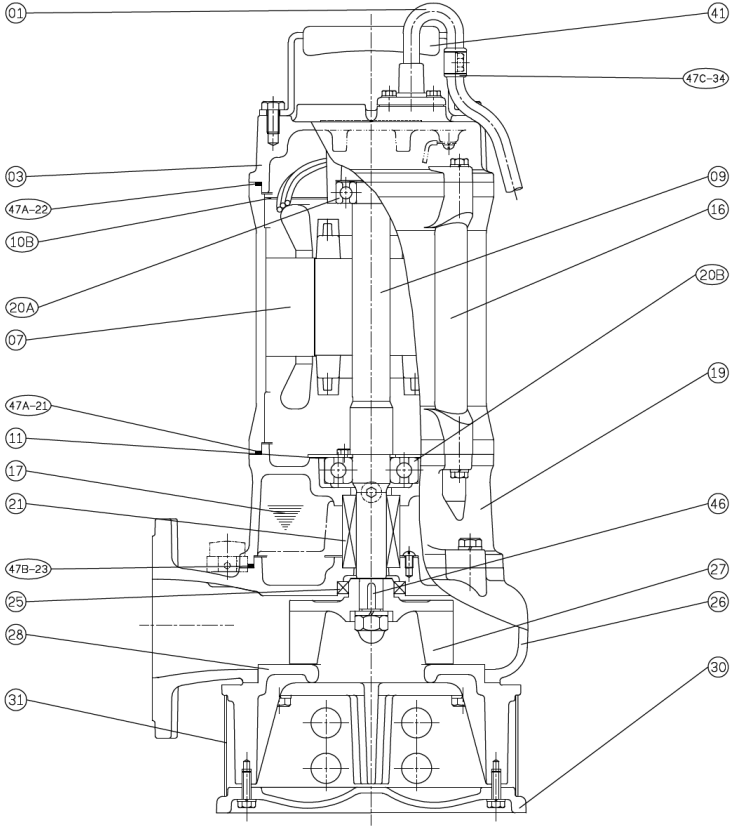

NO.	Part name	Material	QTY
01	Cable		1
03	Upper Cover	FC200	1
07	Stator		1
09	Shaft End	SUS403	1
10B	Protective Plate		1
11	Bearing Fixer	SPCC	1
16	Motor Frame	SUS304	1
17	Lubricant		
19	Bearing Bracket	FC200	1
20A	Bearing		1
20B	Bearing		1
21	M. Seal	CA/CE & SiC/SiC	1
25	Oil Seal	NBR	1
26	Casing	FC200	1

NO.	Part name	Material	QTY
27	Impeller	FC200	1
28	Casing Cover	FC200	1
30	Footing	FC200	1
31	Strainer	SUS304	1
41	Handle	SUS304+NBR	1
46	Impeller Key	SUS304	1
47	Gasket Kit		1

# 9 Parts Drawing

## Three-Phase

3phase 80AL23.7A

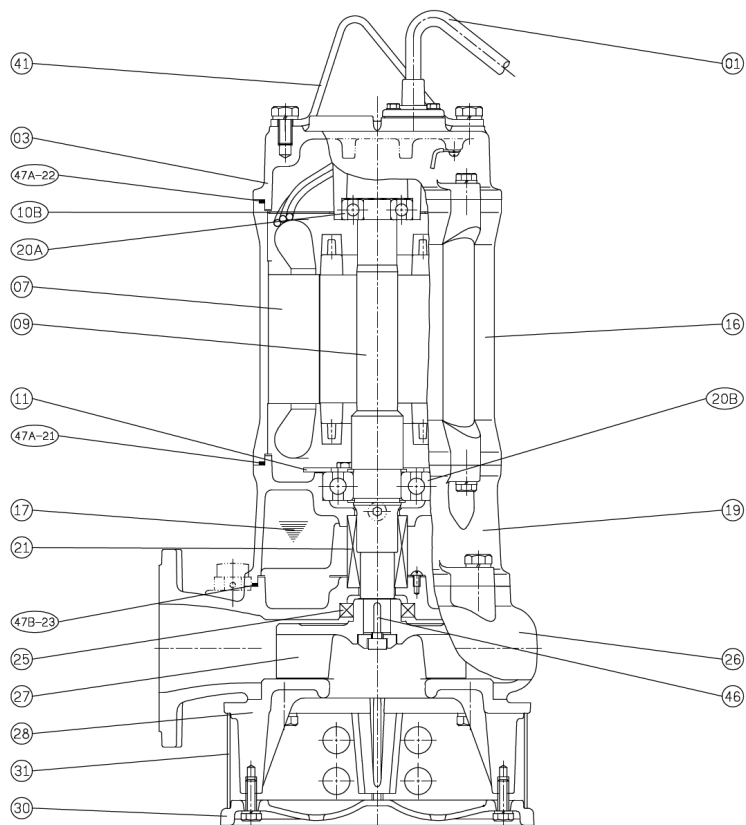

NO.	Part name	Material	QTY
01	Cable		1
03	Upper Cover	FC200	1
07	Stator		1
09	Shaft End	SUS403	1
10B	Protective Plate		1
11	Bearing Fixer	SPCC	1
16	Motor Frame	FC200	1
17	Lubricant		
19	Bearing Bracket	FC200	1
20A	Bearing		1
20B	Bearing		1
21	M. Seal	CA/CE & SiC/SiC	1
25	Oil Seal	NBR	1
26	Casing	FC200	1

NO.	Part name	Material	QTY
27	Impeller	FC200	1
28	Casing Cover	FC200	1
30	Footing	FC200	1
31	Strainer	SUS304	1
41	Handle	SUS304	1
46	Impeller Key	SUS304	1
47	Gasket Kit		

# 9

# Parts Drawing

# Three-Phase

3phase 80(100)AL25.5 / 80(100)AL27.5

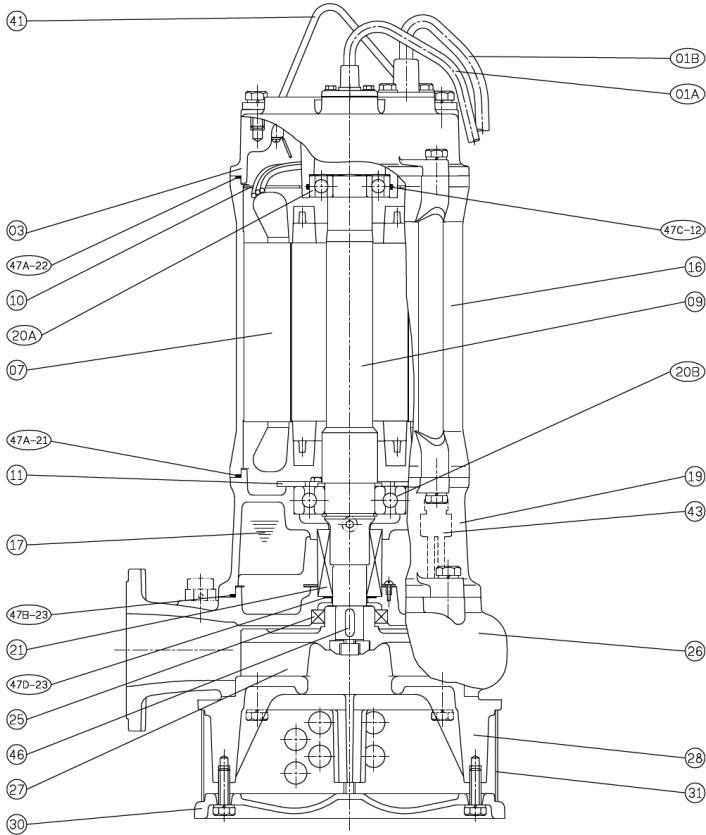

NO.	Part name	Material	QTY
01A	Cable		1
01B	Cable		1
03	Upper Cover	FC200	1
07	Stator (With MTS)		1
09	Shaft End	SUS403	1
10	Protective Plate		1
11	Bearing Fixer	SPCC	1
16	Motor Frame	FC200	1
17	Lubricant		
19	Bearing Bracket	FC200	1
20A	Bearing		1
20B	Bearing		1
21	M. Seal	CA/CE & SiC/SiC	1
25	Oil Seal	NBR	1

NO.	Part name	Material	QTY
26	Casing	FC200	1
27	Impeller	FC200	1
28	Casing Cover	FC200	1
30	Footing	FC200	1
31	Strainer	SUS304	1
41	Handle	SUS304	1
43	Moisture Sensor		1
46	Impeller Key	SUS304	1
47	Gasket Kit		

# 9 Parts Drawing

## Three-Phase

3phase 80(100)AL211

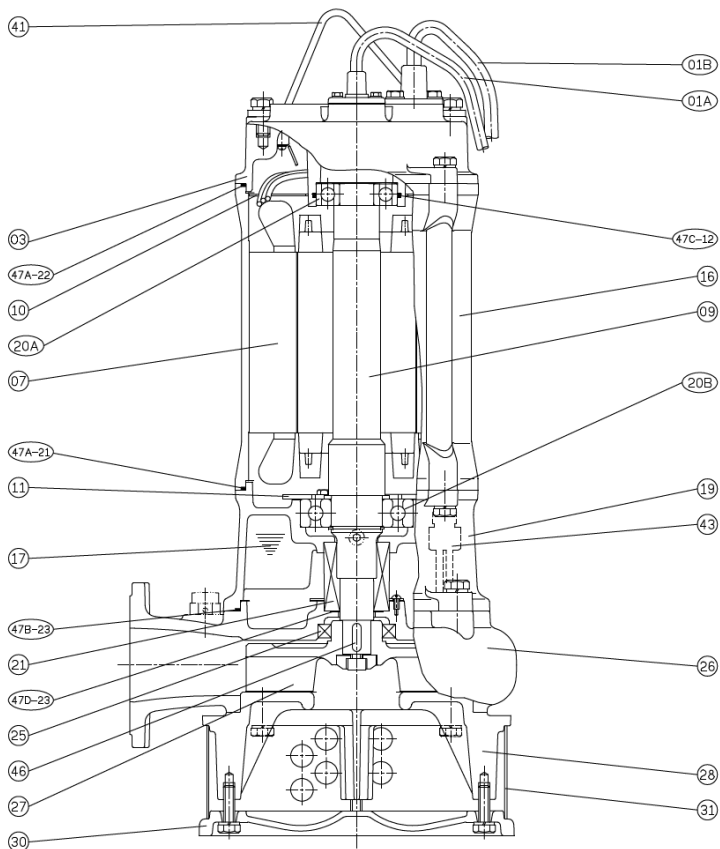

NO.	Part name	Material	QTY
01A	Cable		1
01B	Cable		1
03	Upper Cover	FC200	1
07	Stator (With MTS)		1
09	Shaft End	SUS420J2	1
10	Protective Plate		1
11	Bearing Fixer	SPCC	1
16	Motor Frame	FC200	1
17	Lubricant		
19	Bearing Bracket	FC200	1
20A	Bearing		1
20B	Bearing		1
21	M. Seal	CA/CE & SiC/SiC	1
25	Oil Seal	NBR	1

NO.	Part name	Material	QTY
26	Casing	FC200	1
27	Impeller	FC200	1
28	Casing Cover	FC200	1
30	Footing	FC200	1
31	Strainer	SUS304	1
41	Handle	SUS304	1
43	Moisture Sensor		1
46	Impeller Key	SUS304	1
47	Gasket Kit		

# 10 Electrical Wiring

Single-Phase 208/230/240v

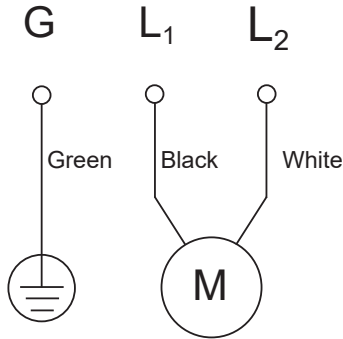

COLORS OF THE CABLE	
	SJOW
L1	Black
L2	White
G	Green

Three-Phase - 1 Power cable  
208/230/240v & 440/460/480v & 575/600v

An electric current must be flowing in a clockwise direction

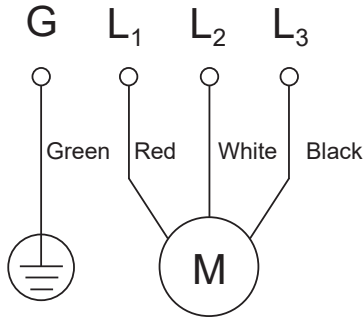

COLORS OF THE CABLE	
	SOW SOOW
L1	Red
L2	White
L3	Black
G	Green

Single-Phase 2~5HP 1 Power, 1 Sensor cable  
208/230/240v With MTS+MS

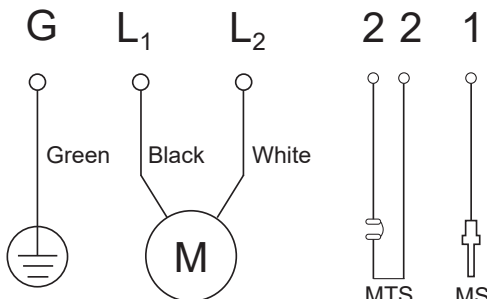

COLORS OF THE CABLE	
	SJOW
L1	Black
L2	White
G	Green

SENSOR CABLE	
MTS	MS Single Probe
2	1
2	G

# 10 Electrical Wiring

Three-Phase 2~5HP 1 Power, 1 Sensor cable  
 208/230/240v & 440/460/480v & 575/600v With MTS+MS

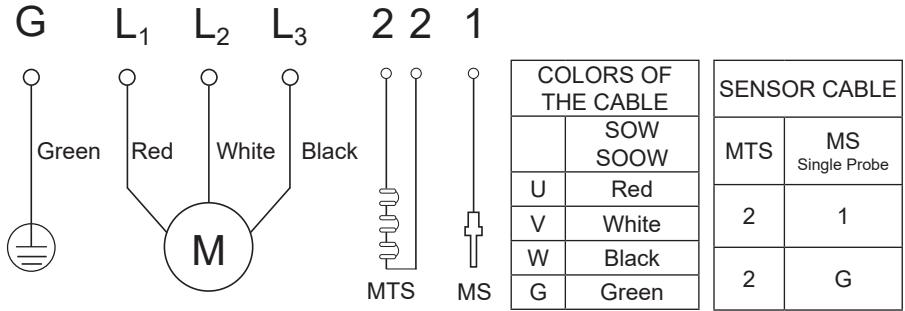

Three-Phase 7.5~15HP 1 Power, 1 Sensor cable  
 208/230/240v & 440/460/480v & 575/600v With MTS+MS

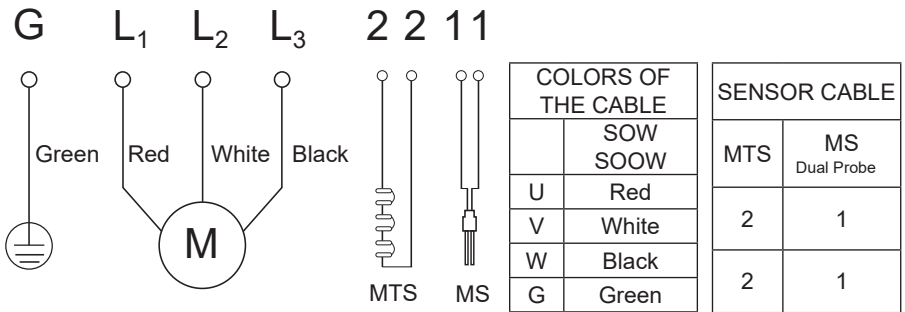

Three-Phase 10~15HP 2 Power, 1 Sensor cable  
 208/230/240v & 440/460/480v & 575/600v With MTS+MS

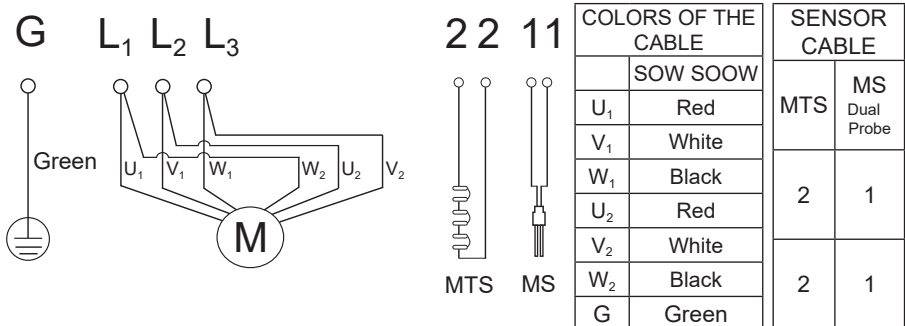

An electric current must be flowing in a clockwise direction on three-phase connection.

## Limited Warranty

1. HCP PUMPS warrants to the original Purchaser only that the Pump/Product ("Pump") will be free of defects in workmanship and material for a period of twelve (12) months from the date of installation or fifteen (15) months from the date of shipment by HCP PUMPS, whichever comes first.
2. This warranty is only available to the direct purchaser of HCP PUMPS products and does not extend to the customer of the purchaser. The warranty of the purchaser's customers is subject to the Purchaser's own warranty.
3. This warranty is valid for a period of fifteen months from the date of delivery shipment from HCP PUMPS.
4. HCP PUMPS warranty shall not apply to products that, in HCP PUMPS' sole judgment, have been subjected to the following circumstances.
  - a) Damages which is caused by negligence, abuse, or accident; or due to improper installation, transportation, or storage; or to unauthorized modification, tampering, or maintenance.
  - b) Damage caused by operating the product outside the HCP instruction manual, the technical, specifications or other published guidelines.
  - c) Damage which is caused by force majeure.
  - d) Damage which is caused by operation in excess of recommended pump performance maximums, other than normal application, operational failures caused by corrosion and rust, or other foreign substance in the system.
  - e) Damage which is caused by used to pump water at a temperature higher than recommended or water containing sand, iron ochre, lime, cement, gravel or other abrasive or corrosive materials, if the product was used to pump chemicals or hydrocarbons or hydrocarbon derivatives (oil, gasoline, solvents, etc.)
  - f) Consumable components, including but not limited to, mechanical seal, oil seal, impeller...etc, cetera, are not covered by the warranty, unless failure has occurred due to a defect in materials or workmanship.
5. This limited warranty covers only replacement for defective component(s). This limited warranty does not cover the relevant labor cost for component replacement and pump repair. The replacement component will be delivered with customer's next pending shipment.
6. In no event shall HCP PUMPS' cost responsibility exceeds the initial purchase pricing paid by the Purchaser for the Pump.
7. This limited warranty does not cover under warranty and is not liable for any loss of costs associated with any extra work caused by defect of the supplied product. Extra work includes but is including but not limited to diagnosing the cause of system problems; servicing HCP products; sorting, improving or re-delivery; personnel travel, transport, work, packaging or material costs; or installation/removal costs in production, in the warehouse or in the field, etc.





make future flow

---

We reserve the right to alter specifications of product at any time without giving prior notice.

**HCP PUMPS**

Efficiency • Professionalism • Service • Commitment

Distributor:

HCP AFP-2201