



SUBMERSIBLE PUMPS

Instruction Manual



BD Series
2 pole (3400rpm)
Submersible Dewatering
Pumps

CSA C22.2 No. 108-14 & UL778



Contents

1.General	1
2.Safety Information	
2.1 Hazard Warning	2
2.2 Hazard Cautions	3
3.Prior to Installation	
3.1 Nameplate	4
3.2 Product Nomenclature	5
3.3 Model Detail	6
4.Installation	
4.1 Pump Mount	7
4.2 Piping	7
4.3 Protection	7
4.4 Electrical	8
4.5 Grounding	9
5.Operation	10
6.Pump Protection Devices	
6.1 Protector Type	11
7.Maintenance	
7.1 General Instruction	12
7.2 Maintenance Schedule routine	12
8.Troubleshooting	13
9.Parts & Drawing	14
10. Wiring Diagram	17
11. Limited Warranty	18

1

General

- Carefully read through and fully understand the User's Instruction Manual before installation and operation.
- Keep User's Instruction Manual in proper and easy access place any time for pump install technician, operator and maintenance technician.
- When damage observed on the product, please contact with authorized local dealers or sales representative.
- Please pay close attention to the 'Warning' , 'Caution' and 'Note' parts of this 'Instruction Manual'.

This is the safety alert symbol. Paying constant attention to safety is always extremely important.



WARNING

Risk of electrical shock - Warning about hazards or unsafe practices which could result in severe personal injury or death.



CAUTIONS

Risk of electrical shock - Warning about hazards that will or can cause minor personal injury or product or property damage.

This Company places heavy emphasis on product quality and safety, however, this Manual does not fully cover all safety matters. For this reason, the user or the maintenance person must pay special attention to their own safety as well.

2 Safety Information

2.1 Hazard Warning



WARNING

Risk of Electric Shock or unsafe practices which could result in severe personal injury or death.

- Use Breaker and ensure the ground wire (Green) is properly grounded by a qualified electrician before operation to avoid fire or personal injury that may be caused by power leakage in the event of motor failure.
- Do not lift, Carry or Hang pump by the electrical cables. Damage to the electrical cable can cause Shock, Burn or death.
- Do not enter the pond during pump operation to avoid personal casualties in case of leakage.
- Use with approved motor control that matches motor input full load amperes with thermal overload relay or adjusted in accordance with control instructions.
- Use with approved liquid level control with correct rating that matches marked motor input in full load amperes or service factor amperes.
- Disconnect the power before servicing.
- The pump is designed for use with inflammable liquids and a non-hazardous environment.
- Do not strain, modify, or any excessive force to the power cable, it can damage the cable and cause short circuit and even lead to electrocution or fire.
- Do not install the pump into any location classified as hazardous environment.
- Do not used this pump in swimming pools or marine areas.

2 Safety Information

2.2 Hazard Cautions

CAUTIONS

Risk of Electric Shock that will or can cause minor personal injury or product or property damage.

- To reduce risk of electric shock, pull plug before servicing this pump.
- Inspect your pump for damage that may have occurred during shipment.
- Inspect the pump for any cracks, dents, damage threads.
- Check power cord for any cuts or damage.
- If in a climate where the fluid in the casing could freeze, never leave liquid in the pump casing. Drain the casing complete. During winter months and cold weather, the liquid could freeze and damage the pump casing.
- Do not run the equipment dry or start the pump without the casing flooded.
- The pump shaft **MUST** turn clockwise when viewed from the motor end. It is absolutely essential that the rotation of the motor be checked before installation and starting the pumps. Incorrect rotation of the pump can unscrew the impeller nut and cause severe damage to pumping assembly.
- The applicable pumping liquid temperature should be 0-40°C, and the pump may be damaged if exceeding such range.
- The pH value of water for the operation should be between 5~9.
- Power supply voltage tolerance is within $\pm 10\%$ of the rated voltage.
- Vent sewage and septic tank according to local requirements or standards.
- Check proper oil level in seal chamber periodically. Check for water in the seal housing periodically.
- A three-phase cord-connected submersible pump, must have a motor control and liquid level control provided at time of installation. The control device should have suitable voltage, ampere, frequency, grounding and horsepower rating for the pump to which it is connected.
- Remove the oversized substance suspended in water before operating the pump to prevent clogging and inadequate water volume. Make sure that the size of the substance suspended in water is smaller than the solid passage of the pump. The substance must be able to go through the strainer and the impeller.

3 Prior to Installation

- Check if the product, spare parts and accessories free from defect or damage.
- Check carefully items correspond to the 'Nameplate' Nameplate show on pump, and to be sure that model, output (motor horsepower), Voltage are all correct. Don't operate pump if any of Nameplate information does not match to your specification.
- Do not operate this pump under any conditions or applications other than those which have been mentioned in this Instruction Manual.

3.1 Nameplate

Every pump has its own 'nameplate' (see Figure 1). Make sure that the 'Model Name', 'Output' (horsepower), 'Voltage', 'Frequency', 'Phase' and 'rpm' information are correct. Contact authorized local dealer or HCP sales representative If you have any questions regarding the 'nameplate'.

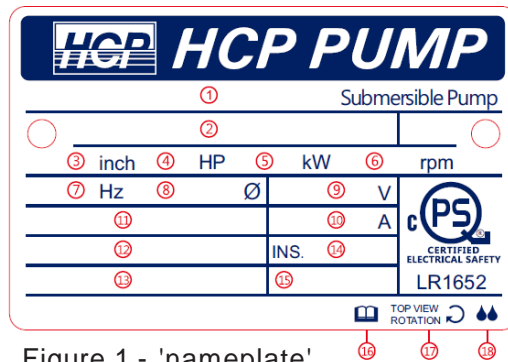

Figure 1 - 'nameplate'

1	Serial number / Date	10	Rated current
2	Model Name	11	Min. head
3	Discharge	12	Max. head
4	Rated output horse power	13	Flow
5	Rated output kW	14	Insulation class
6	Rated rotation speed	15	Thermally Protected
7	Frequency	16	Read instruction manual
8	Phase	17	Direction of rotation
9	Rated Voltage	18	Watertight submersible pump

Note: Panel nameplate marked "For Panel only" is provided along with instruction manual. Please place panel nameplate at control panel without plug or near receptacle for pump with plug.

3

Prior to Installation

3.2 Product Nomenclature

100	BD	2	22	-	6	35	O	E	X
-----	----	---	----	---	---	----	---	---	---

Pump Discharge

100 = 100mm = 4inch, 100(150) = 100mm(150mm) = 4inch(6inch), 150 = 150mm = 6inch

Pump Series

BD Series Submersible Dewatering pumps

Pole

2=2 pole (3400rpm)

Motor kW

22= 22kW (30HP)

Frequency

6 = 60Hz

Phase/Voltage

3C= 3phase 208, 3E = 3phase 230v, 3F= 3phase 440v, 3G= 3pahse 460v, 34= 3phase 480v, 35 = 3phase 575v, 36 = 3phase 600v

Cable code (*)

O = SOW / SOOW Cable

Cable length (#)

E = 30ft, G = 50ft, H = 60ft, J = 70ft, K = 80ft, L = 90ft, M = 100ft, X = 120ft, O = 150ft

Protection

T = MTS (Motor Thermal Sensor), M = MS (Moisture Sensor)
S = MTS + MS, X = Without Thermal protector or Sensor

3

Prior to Installation

3.3 Model Detail

Model	Horse Power	Phase	Hz	Volts	FLA	Discharge
	HP(kW)					Inch
100BD222-634 * # X	30 (22)	3	60	480	34.4	4
100BD222-634 * # S	30 (22)	3	60	480	34.4	4
100BD222-635 * # X	30 (22)	3	60	575	27.5	4
100BD222-635 * # S	30 (22)	3	60	575	27.5	4
150(200)BD222-634 * # X	30 (22)	3	60	480	34.4	6
150(200)BD222-635 * # X	30 (22)	3	60	575	27.5	6
150BD222-634 * # X	30 (22)	3	60	480	34.4	6
150BD222-634 * # S	30 (22)	3	60	480	34.4	6
150BD222-635 * # X	30 (22)	3	60	575	27.5	6
150BD222-635 * # S	30 (22)	3	60	575	27.5	6

Remark:

Cable code (*): 7 = SJOW + US 3prong plug, L = SJOW Cable, O = SOW / SOOW Cable

Cable length (#): 3 = 10ft, 5 = 15ft, 6 = 20ft, 8 = 25ft, E = 30ft, G = 50ft, H = 60ft, J = 70ft, K = 80ft, L = 90ft,
M = 100ft, X = 120ft, O = 150ft

4 Installation

4.1 Pump Mount

- All pumps as a free standing unit. Set the pump on the floor of the basin.
- Several series of pumps may install on Guide Rail System for ease lift out inspection and service. Guide rails allow removal of the pump without disturbing the piping or require personnel to enter the wet well. (Contact with local dealer or manufacturer for appropriate Guide Rail System).
- Install the Guide Rail on hard level surface cement, asphalt, etc. Never place the pump directly on earth, clay or gravel surfaces.

4.2 Piping

- All piping must be independently supported, accurately aligned and be capable of handling semi-solids.
- Reduce the number of bends or turns in the discharge piping to keep the outlet flow as smooth as possible.
- All pump models covered in this manual are intended for use in a wet, flooded sump. Due to this intended service, no suction piping is required.
- The piping must not be smaller than pump discharge.
- Install checkvalve to prevent pump damage from water hammer.

4.3 Protection

- Pump model equipped with MTS – Motor Thermal Sensor (Normal: closed; abnormal: open) require connect lead wires marked 2 & 2 with the control circuit or control relay to protect motor from overheating and cause motor failure. Failure to connect MTS will void the warranty on the unit.
- Pump model equipped with MS - Moisture Sensor require to be connected on lead wires marked 1 & 1 to control relay which circuit is (Normal Open; abnormal Close), to sense moisture in mechanical seal chamber cause seals failure. To prevent water penetrates motor to causes electric leakage and burn the motor
- Pump must install on dedicated earth leakage circuit breaker and a thermal overload relay.

4

Installation

4.4 Electrical



WARNING

Risk of Electric Shock - Electricity is dangerous. It can burn, shock or cause death. When installing, operating or servicing this pump, following the instruction below.

- Use with approved motor control that matches motor input in full load amperes with thermal overload relay or adjusted in accordance with control instructions.
- DO NOT splice the power cord.
- Do not remove power supply cord and strain relief or connect conduit directly to the pump.
- DO NOT operate the pump and motor unless it is properly grounded. Wire the pump directly to a grounded terminal block in automatic float or pump control panel, at least the size of the circuit conductors supplying the pump, to the grounding screw provided within the wiring compartment. Be sure to follow all local electrical codes here the unit is installed.
- Make sure the supply frequency and voltage corresponds to the nameplate frequency and voltage requirements. Supply voltage must be within 10% of nameplate voltage. Incorrect voltage can seriously damage the motor and could cause fire which would invalidate the warranty. If in doubt consult a licensed electrician.
- Pump must rotate in a clockwise direction (viewed from the motor end). Never operate pump and motor in reverse. If a three phase unit runs backwards, interchange two of three power supply wires to reverse the motor's direction of rotation.
- Connect the pump to its own circuit with nothing else on the same circuit.
- Install the pump in accordance with the National Electrical Codes ANSI/NFPA 70. Install a fused disconnect switch or a circuit breaker.
- Pump without Thermal protector must install on dedicated earth leakage circuit breaker and a thermal overload relay.
- Install only on a circuit protected by a Ground-Fault Circuit-Interrupted (GFCI) for pump cord with plug
- Connect only to a properly grounded, grounded type receptacle.

4 Installation

4.5 Grounding



WARNING

Risk of Electric Shock - during operation of this pump requires the provision of acceptable grounding:

- When the means of connection to the supply-connection box is other than grounded metal conduit, ground the pump back to the service by connecting a copper conductor, at least the size of the circuit conductors supplying the pump, to the grounding screw provided within the wiring compartment.
- This pump is provided with a means for grounding. To reduce the risk of electric shock from contact with adjacent metal parts, bond supply box to the pump-motor-grounding means and to all metal parts accessible at the well head, including metal discharge pipes, metal well casing, and similar parts, by means of an equipment-grounding conductor at least the size of the well-cable conductors, or the equivalent, that runs down the well with the well cable and.
- For a cord and plug-connected pump, the word "WARNING" and the following instructions or the equivalent: "Risk of electric shock – This pump is supplied with a grounding conductor and grounding-type attachment plug. To reduce the risk of electric shock, be certain that it is connected only to a properly grounded, grounding-type receptacle."

5 Operation

DANGER

Do not operate this pump where explosive or flammable material area. Serious personal injury, death, or major property damage will result.

WARNING

Hazardous impeller and possible unexpected starts. Rotation of the impeller with hands can cause loss of fingers. Disconnect the electrical power before working on or handling the pump for any reason.

- It is absolutely essential that the rotation of the pump be checked.
- All the pumps covered in this manual turn clockwise as viewed from motor end.
- If the thermal overload trips frequently, check for the cause. It could be impeller block, wrong/ low voltage, electrical failure in the motor.
- Pump must stop before the liquid level reach Pump Lowest Water Level (L.W.L.)
- Pump operation is limited to 5 ~ 10 minutes at or below Continuous Water Level (C.W.L.)
- DO NOT allow the pump to run in a dry sump. It will void the warranty and maybe damage the pump.
- Install the pump in accordance with the National Electrical Codes. Use with approved motor control that matches motor input full load amperes with thermal overload relay or adjusted in accordance with control instructions.
- Select the piping that fits to the flow capacity of the pump. Inappropriate piping (too large or too small) can result in excessive noise and vibration during pump's operation.
- Make sure the vales of the pipe line operate normally and check if the flow capacity is correct. Air might be gathering in the check valve if pump is operating without discharging the water. The air has to be released if air pocket is found at the check valve.

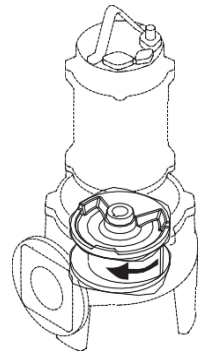

6

Pump Protection Devices

6.1 Protector Type (Optional 30HP)

- Motor Thermal Sensor (MTS)

MTS embedded in each phase of stator winding embedded sensor (Normal: closed; Abnormal :open). Note: MS comes with 2 leads marked with “2” on the cable.

- Moisture Sensor (MS)

MS equipped in Mechanical Seal Lubricant chamber (Normal: open; Abnormal :close). Note: MS comes with 2 leads marked with “1” on the cable.

Caution

When the sensor activates an alarm, stop using the pump immediately and call authorized dealer or HCP representative. The warranty is void if pump damage is caused by failure to connect the protector or by continued operation after alarm activation.

7 Maintenance

Only qualified mechanics with proper tools and knowledge should attempt to service this pump.

7.1 General Instruction

CAUTIONS

Warning about hazards that will or can cause minor personal injury or product or property damage.

It must be very careful when disassemble and replace new o-ring for assembling the motor and mechanical seal chamber. Improper assembling may impair the waterproof and cause motor burn by leakage and will void the warranty.

WARNING

Hazardous voltage can shock, burn, or kill. Disconnect the electrical power before attempting any service or work on pump.

7.2 Maintenance Schedule routine

Daily	<ol style="list-style-type: none"> 1. Operating Current: within range of current rating 2. Operating Voltage: within a safe range ($\pm 10\%$ of rated voltage) 3. Check the output flow rate for it's normal value.
Monthly	Check the insulation, if it is lower than $20M\Omega$ (with a 500V megger), maintenance is recommended. Replace new motor immediately when insulation is lower than $1M\Omega$.
Annually	<p>Inspect lubricant::</p> <p>For pumps should be checked every 6000 hours or 12 months (whichever comes first).</p> <p>[Remarks]</p> <p>Loosen the oil plug screw and check the color of the lubricant. If the lubricant looks unclear, please change the mechanical seal and the lubricant immediately. Apply adhesive before re-securing the oil plug screw to strengthen the screw against leakage.</p> <p>Oil specifications: VG32 or equivalent.</p>
Every 2 to 5 years	<ol style="list-style-type: none"> 1. Strongly recommended the pump to be overhaul or regular inspection even if it is still operating. This maintaining procedure can extend pump operating life cycle. 2. Please contact your authorized local dealers or HCP for such service.

8 Troubleshooting

WARNING

Hazardous voltage can shock, burn, or kill. Disconnect the electrical power before attempting any service or repair work on pump.

SYMPTOM	POSSIBLE CAUSE	RECOMMENDED SOLUTION
Pump Not Operating	Power failure	Check power and correct connection.
	Defective cable	Replace power cable.
	Impeller clogged	Remove the foreign objects from impeller or casing.
	Bad Motor Protector	Replace new motor protector.
	The motor burnout	Rewind or Replace newmotor.
	Float switch defective	Replace new float switch.
	Bad Control Panel	Repair or replaced.
Pump stop during operation	Impeller Jammed	Remove the foreign objects from impeller or casing.
	Abnormal voltage	Check the power and make sure it corresponds to the nameplate.
	The motor protector tripped	Make sure liquid temperature is below 40°C \ pump is completely submerged.
Pump not reaching design Flow rate	Incorrect rotation	Reverse two of three leads on a three phase motor.
	Worn and damaged impeller or cavitation	Replace new impeller.
	The block of strainer	Remove the foreign objects from impeller or casing.
	Objects inside the pump or the impeller	Remove the foreign objects from impeller or casing.
	Valves and pipe plugged	Remove plugged objects or replace new valves or pipes.
	System head excessive	Consult dealer.
	Cavitations	Reposition liquid level control.
Electric Leakage Circuit Breaker Activated	Power cable damaged	Replace new Cable.
	Wet cable terminal	Reconnect after drying out.
	Worn mechanical seal cause water enter	Replace new Mechanical seals and oil seal.
	The motor burns	Replace new motor.
Abnormal High Amperage	Abnormal voltage	Check the power and make sure it corresponds to the nameplate.
	Incorrect rotation	Reverse two of three leads on a three phase motor.
	High viscosity liquid	More liquid needs to be added to the pump fluid to decrease its viscosity.
	Objects inside the pump or the impeller	Remove the foreign objects from impeller or casing.
	Defective bearings	Replace new bearing.

10 Electrical Wiring

3Phase 30HP 1 Power cable
440/460/480v & 575/600v

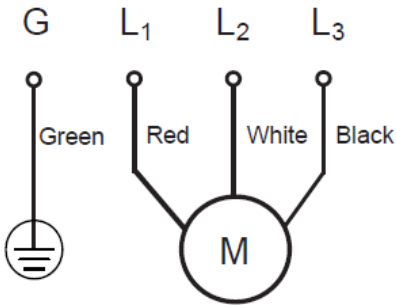

COLORS OF THE CABLE	
	SOW SOOW
L1	Red
L2	White
L3	Black
G	Green

3Phase 30HP 1 Power, 1 Sensor cable
440/460/480v & 575/600v With MTS+MS

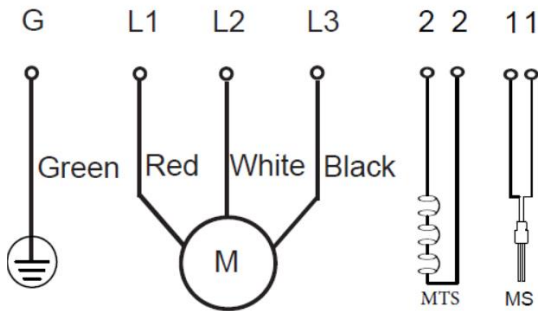

COLORS OF THE CABLE	
	SOW SOOW
U	Red
V	White
W	Black
G	Green

SENSOR CABLE	
MTS	MS Double Probe
2	1
2	1

Limited Warranty

1. HCP PUMPS warrants to the original Purchaser only that the Pump/Product ("Pump") will be free of defects in workmanship and material for a period of twelve (12) months from the date of installation or Fifteen (15) months from the date of shipment by HCP PUMPS, whichever comes first.
2. This warranty is only available to the direct purchaser of HCP PUMPS products and does not extend to the customer of the purchaser. The warranty of the customer of the purchaser is subject to the purchaser's own warranty.
3. This warranty is valid for a period of fifteen months from the date of delivery shipment from HCP PUMPS.
4. HCP warranty shall not apply to products that, in HCP PUMPS sole judgment, has been subjected to the following circumstances.
 - a) Damages which is caused by negligence, abuse, or accident; or due to improper installation, transportation or storage; or to un-authorized modification, tampering or maintenance.
 - b) Damage caused by operating the product outside the HCP instruction manual, the technical specifications or other published guidelines;
 - c) Damage which is caused by force majeure.
 - d) Damage which is caused by operation in excess of recommended pump performance maximums, other than normal application, operational failures caused by corrosion and rust, or other foreign substance in the system.
 - e) Consumable components, including but not limited to, mechanical seal, oil seal, impeller...et cetera, are not covered by the warranty, unless failure has occurred due to a defect in materials or workmanship
 - f) Consumable components, including but not limited to, mechanical seal, oil seal, impeller...etc, cetera, are not covered by the warranty, unless failure has occurred due to a defect in materials or workmanship.
5. This limited warranty covers only replacement for defective component. This limited warranty does not cover the relevant labor cost for component replacement and pump repair. The replacement component is to be delivered with customer's next pending shipments.
6. In no event shall HCP PUMPS's cost responsibility exceed the initial purchase pricing paid by the Purchaser for the Pump.
7. This limited warranty does not cover under warranty and is not liable for any loss of costs associated with any extra work caused by defect of the supplied product. The extra work is including but not limited to diagnosing the cause of system problem; servicing HCP products; sorting, improving or re-delivery; personnel travel, transport, work, packaging or material costs; or installation/removal costs in production, in the warehouse or in the field...et cetera.



make future flow

We reserve the right to alter specifications of product at any time without giving prior notice.



HCP PUMPS

Efficiency • Professionalism • Service • Commitment

Distributor:

HCP AFC-2201