



SUBMERSIBLE PUMPS

Instruction Manual



A Series Wastewater / Sump Submersible Pumps

CSA C22.2 No. 108-14 & UL778



Thank you for using HCP Submersible Pump.

Contents

1.General	1
2.Safety Information	
2.1 Hazard Warning	2
2.2 Hazard Cautions	3
3.Prior to Installation	
3.1 Nameplate	4
3.2 Product Nomenclature	5
3.3 Model Detail	6
4.Installation	
4.1 Pump Mount	7
4.2 Piping	7
4.3 Protection	7
4.4 Electrical	8
4.5 Grounding	9
5.Operation	10
6.Maintenance	
6.1 General Instruction	11
6.2 Maintenance Schedule routine	11
7.Troubleshooting	12
8.Parts & Drawing	
8.1 1phase A-05B	13
8.2 1phase A-05L	14
8.3 1phase A-21	15
8.4 1phase A-31	16
8.5 1phase A-23H/33H	17
8.6 3phase A-05B	18
8.7 3phase A-05L/21	19
8.8 3phase A-31	20
9.Wiring Diagram	21
10.Limited Warranty	22

1

General

- Carefully read through and fully understand the User's Instruction Manual before installation and operation.
- Keep User's Instruction Manual in proper and easy access place any time for pump install technician, operator and maintenance technician.
- When damage observed on the product, please contact with authorized local dealers or sales representative.
- Please pay close attention to the 'Warning' , 'Caution' and 'Note' parts of this 'Instruction Manual'.

This is the safety alert symbol. Paying constant attention to safety is always extremely important.



WARNING

- **Risk of electrical shock** - Warning about hazards or unsafe practices which could result in severe personal injury or death.



CAUTION

- **Risk of electrical shock** - Warning about hazards that will or can cause minor personal injury or product or property damage.

This Company places heavy emphasis on product quality and safety, however, this Manual does not fully cover all safety matters. For this reason, the user or the maintenance person must pay special attention to their own safety as well.

2

Safety Information

2.1 Hazard Warning

WARNING

Risk of Electric Shock or unsafe practices which could result in severe personal injury or death.

- Use Breaker and ensure the ground wire (Green) is properly grounded by a qualified electrician before operation to avoid the risk of fire or personal injury that may cause by power leakage in the event of motor failure.
- Do not lift, Carry or Hang the pump by the electrical cables. Damage to the electrical cable can cause Shock, Burn or death.
- Do not enter the pond during pump operation to avoid personal casualties in the event of leakage.
- Use an approved motor control that matches motor input full load amperes with thermal overload relay or adjusted in accordance with the control instructions.
- Use an approved liquid level control with correct rating that matches marked motor input in full load amperes or service factor amperes.
- Disconnect the power before servicing.
- The pump is designed for use with inflammable liquids and a non-hazardous environment.
- Do not strain, modify, or any excessive force to the power cable, it can damage the cable and cause short circuit and even lead to electrocution or fire.
- Do not install the pump into any location classified as hazardous environment.
- Do not use this pump in swimming pools or marine areas.

2.2 Hazard Cautions

CAUTION

Risk of Electric Shock that will or can cause minor personal injury, product or property damage.

- To reduce the risk of electric shock, pull the plug before servicing on the pump.
- Inspect your pump for damage that may have occurred during shipment.
- Inspect the pump for any cracks, dents, or damage threads.
- Check power cord for any cuts or damage.
- If in a climate where the fluid in the casing could freeze, never leave liquid in the pump casing. Drain the casing complete. During winter months and cold weather, the liquid could freeze and damage the pump casing.
- DO NOT run the equipment dry or start the pump without the casing flooded.
- The pump shaft MUST turn clockwise when viewed from the motor end. It is absolutely essential that the rotation of the motor be checked before installation and starting the pumps. Incorrect rotation of the pump can unscrew the impeller nut and cause severe damage to pumping assembly.
- The applicable pumping liquid temperature should be 32-104 °F (0-40 °C), and the pump may be damaged if exceeding such range.
- The pH value of liquid for the operation should be between 5~9.
- Power supply voltage tolerance is within $\pm 10\%$ of the rated voltage.
- Vent sewage and septic tank according to local requirements or standards.
- Check proper oil level in seal chamber periodically. Check for water in the seal housing periodically.
- A three-phase cord-connected or a single-phase cord connected sewage, effluent, and grinder submersible pump, must have a motor control and liquid level control provided at time of installation. The control device should have suitable voltage, ampere, frequency, grounding and horsepower rating for the pump to which it is connected.
- Remove the oversized substance suspended in water before operating the pump to prevent clogging and inadequate water volume. Make sure that the size of the substance suspended in water is smaller than the solid passage of the pump. The substance must be able to go through the strainer and the impeller.

3 Prior to Installation

- Check if the product, spare parts and accessories free from defect or damage.
- Check carefully all items correspond to the 'Nameplate' of the pump, including the model, output (motor horsepower), and voltage are all correct. Do not operate the pump if any of Nameplate information is not line with your specification.
- DO NOT operate this pump under any conditions or applications other than those which have been mentioned in this Instruction Manual.

3.1 Nameplate

- Every pump has its own 'Nameplate' (see Figure 1). Make sure the information including 'Model Name', 'Output' (horsepower), 'Voltage', 'Frequency', 'Phase' and, 'rpm' information are correct. Contact an authorized local dealer or HCP sales representative if you have any questions regarding the 'Nameplate'.

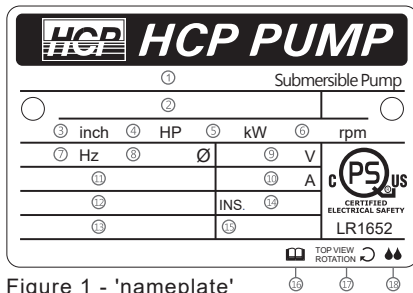

Figure 1 - 'nameplate'

1	Serial number / Date	10	Rated current
2	Model Name	11	Min. head
3	Discharge	12	Max. head
4	Rated output horsepower	13	Flow
5	Rated output kW	14	Insulation class
6	Rated rotation speed	15	Thermally Protected
7	Frequency	16	Read instruction manual
8	Phase	17	Direction of rotation
9	Rated Voltage	18	Watertight submersible pump

Note: Panel nameplate marked "For Panel only" is provided along with instruction manual. Please place the panel nameplate on the control panel without a plug or near the receptacle for the pump with a plug.

3.2 Product Nomenclature

A - 2 1 - 6 12 L E P

Pump Series

A Series Wastewater

Pump Discharge

Blank = 2inch (50mm), 2 = 2inch (50mm)
3 = 3inch (80mm), 4 = 4inch (100mm)

Motor HP

0.5 = 0.5HP (0.4kW), 1 = 1HP (0.75kW)
1.5 = 1.5HP(1.1kW), 2 = 2HP (1.5kW)
3 = 3HP (2.2kW), 4 = 4HP (3.0kW)
5 = 5HP (3.7kW)

Impeller Type

Blank(), H

Version

Blank(), B, L

Float

Blank(), F

Frequency

6 = 60Hz

Phase/Voltage

1A = 1phase 110v, 1B = 1phase 115v, 11 = 1phase 120v, 1C = 1phase 208v
1D = 1phase 220v, 1E = 1phase 230v, 12 = 1phase 240v, 3C = 3phase 208v
3D = 3phase 220v, 3E = 3phase 230v, 32 = 3phase 240v, 3F= 3phase 440v
3G = 3phase 460v, 34 = 3phase 480v, 35 = 3phase 575v, 36 = 3phase 600v

Cable code (*)

7 = SJOW + US 3prong plug, L = SJOW Cable, O = SOW / SOOW Cable

Cable length (#)

6 = 20ft, 8 = 25ft, E = 30ft, G = 50ft, H = 60ft, J = 70ft
K = 80ft, L = 90ft, M = 100ft, X = 120ft, O = 150ft

Protection

P= Thermal protector, T = MTS (Motor Thermal Sensor), M = MS (Moisture Sensor)
S = MTS + MS, X = Without Thermal protector or Sensor

3.3 Model Detail

Model	horsepower HP(kW)	Phase	Hz	Volts	FLA	Discharge Inch
A-05B-611 * #P	0.5 (0.37)	1	60	120	5.2	2
A-05B-612 * #P	0.5 (0.37)	1	60	240	2.6	2
A-05B-632 * #X	0.5 (0.37)	3	60	240	1.8	2
A-05B-634 * #X	0.5 (0.37)	3	60	480	0.9	2
A-05B-635 * # X	0.5 (0.37)	3	60	575	0.7	2
A-05B F-611 * #P	0.5 (0.37)	1	60	120	5.2	2
A-05B F-612 * #P	0.5 (0.37)	1	60	240	2.6	2
A-05L-611 * #P	0.5 (0.37)	1	60	120	6.2	2
A-05L-612 * #P	0.5 (0.37)	1	60	240	3.1	2
A-05L-632 * #X	0.5 (0.37)	3	60	240	2.2	2
A-05L-634 * #X	0.5 (0.37)	3	60	480	1.1	2
A-05L-635 * # X	0.5 (0.37)	3	60	575	0.9	2
A-05L F-611 * #P	0.5 (0.37)	1	60	120	6.2	2
A-05L F-612 * #P	0.5 (0.37)	1	60	240	3.1	2
A-21-611 * #P	1 (0.75)	1	60	120	9.6	2
A-21-612 * #P	1 (0.75)	1	60	240	4.8	2
A-21-632 * #X	1 (0.75)	3	60	240	3.3	2
A-21-634 * #X	1 (0.75)	3	60	480	1.6	2
A-21-635 * # X	1 (0.75)	3	60	575	1.3	2
A-21 F-611 * #P	1 (0.75)	1	60	120	9.6	2
A-21 F-612 * #P	1 (0.75)	1	60	240	4.8	2
A-23H-612 * #X	4 (3.0)	1	60	240	18	2
A-31-611 * #P	1 (0.75)	1	60	120	9.6	3
A-31-612 * #P	1 (0.75)	1	60	240	4.8	3
A-31-632 * #X	1 (0.75)	3	60	240	3.3	3
A-31-634 * #X	1 (0.75)	3	60	480	1.6	3
A-31-635 * # X	1 (0.75)	3	60	575	1.3	3
A-31 F-611 * #P	1 (0.75)	1	60	120	9.6	3
A-31 F-612 * #P	1 (0.75)	1	60	240	4.8	3
A-33H-612 * #X	4 (3.0)	1	60	240	18	3

Remark:

Cable code (*): 7 = SJOW + US 3prong plug, L = SJOW Cable, O = SOW / SOOW Cable

Cable length (#): 6 = 20ft, 8 = 25ft, E = 30ft, G = 50ft, H = 60ft, J = 70ft, K = 80ft, L = 90ft, M = 100ft, X = 120ft, O = 150ft

4

Installation

4.1 Pump Mount

- All pumps as a free-standing unit. Set the pump on the floor of the basin.
- Several series of pumps can be installed on the Guide Rail System for easier lift out for inspecting and servicing purposes. The Guide Rails allow removal of the pump without disturbing the piping or require personnel to enter the wet well. Contact the local dealer or HCP sales representative for the appropriate Guide Rail System.
- Install the Guide Rail on hard level surface such as cement, asphalt, etc. Never place the pump directly on earth, clay or gravel surfaces.

4.2 Piping

- All piping must be supported independently supported, accurately aligned, and be capable of handling semi-solids.
- Reduce the number of bends or turns in the discharge piping for maintaining smooth outlet flow.
- All pump models covered in this manual are designed to be used in a wet, flooded sump. Due to this intended service, no suction piping is required.
- The piping must not be smaller than pump discharge.
- Install a check valve to prevent pump damage caused by water hammer.

4.3 Protection

- Pump model equipped with Motor Thermal Sensor (MTS) – MTS (Normal: closed; abnormal: open) requires connect lead wires marked 2 & 2 with the control circuit or control relay to protect the motor from overheating and cause motor failure. Failure to connect MTS will void the warranty on the unit.
- Pump model equipped with Moisture Sensor (MS) – MS (Normal Open; abnormal Close) requires to be connected on the lead wires marked 1 & 1 to control the relay circuit, allowing the sensor to detect any moisture in mechanical seal chamber which may cause seals failure. To prevent water penetrates motor to causes electric leakage and burn the motor.
- Pump must install on a dedicated earth leakage circuit breaker and a thermal overload relay.

4.4 Electrical



WARNING

Risk of Electric Shock - Electricity is dangerous. It can lead to burn, shock, or cause death. When installing, operating or servicing this pump, following the instruction below.

- Use an approved motor control that matches motor input in full-load amperes with a thermal overload relay or adjust it according to the control instructions.
- DO NOT splice the power cord.
- DO NOT remove power supply cord and strain relief or connect conduit directly to the pump.
- DO NOT operate the pump and motor unless it is properly grounded. Wire the pump directly to a grounded terminal block in automatic float or pump control panel that is at least the size of the circuit conductors supplying the pump, and to the grounding screw provided within the wiring compartment. Be sure to follow all local electrical codes where the unit is installed.
- Make sure the supply frequency and voltage corresponds to the frequency and voltage requirements on the Nameplate. The supply voltage must be within 10% of the Nameplate voltage. Incorrect voltage can cause serious damage to the motor and could result in a fire, which would invalidate the warranty. If in doubt consult a licensed electrician.
- Pump must rotate in a clockwise direction (viewed from the motor end). Never operate pump and motor in reverse. If a three phase unit is running backwards, interchange two of the three power supply wires to reverse the motor's direction of rotation.
- Connect the pump to its own circuit with nothing else on the same circuit.
- Install the pump in accordance with the National Electrical Codes ANSI/NFPA 70. Install a fused disconnect switch or a circuit breaker.
- Pumps without Thermal protector must install on dedicated earth leakage circuit breaker and a thermal overload relay.
- Install only on a circuit protected by a Ground-Fault Circuit-Interrupted (GFCI) for pump cord with plug.
- Connect only to a properly grounded, grounded type receptacle.

4.5 Grounding

WARNING

Risk of Electric Shock - during operation of this pump requires the provision of acceptable grounding:

- When the means of connection to the supply-connection box is other than grounded metal conduit, ground the pump back to the service by connecting a copper conductor, at least the size of the circuit conductors supplying the pump, to the grounding screw provided within the wiring compartment.
- This pump is provided with a means for grounding. To reduce the risk of electric shock from contact with adjacent metal parts, bond supply box to the pump-motor-grounding means and to all metal parts accessible at the well head, including metal discharge pipes, metal well casing, and similar parts, by means of an equipment-grounding conductor at least the size of the well-cable conductors, or the equivalent, that runs down the well with the well cable and.
- For a cord and plug-connected pump, the word "WARNING" and the following instructions or the equivalent: "Risk of electric shock – This pump is supplied with a grounding conductor and grounding-type attachment plug. To reduce the risk of electric shock, be certain that it is connected only to a properly grounded, grounding-type receptacle."

5 Operation

⚠ DANGER

Do not operate this pump in areas where explosive or flammable materials are present. Serious personal injury, death, or major property damage will result.

⚠ WARNING

Hazardous impellers and the possibility of unexpected starts, rotating the impeller with hands can cause loss of fingers. Disconnect the electrical power before working on or handling the pump for any reason.

- It is absolutely essential that the rotation of the pump be checked.
- All the pumps covered in this manual turn a clockwise direction as viewed from the motor end.
- If the thermal overload trips frequently, check for the cause. It could be impeller blockage, wrong / low voltage, or electrical failures in the motor.
- Pump must stop before the liquid level reach the pump's Lowest Water Level (L.W.L.)
- Pump operation is limited to 5 ~ 10 minutes at or below Continuous Water Level (C.W.L.)
- DO NOT allow the pump to run in a dry sump. It will void the warranty and may damage the pump.
- Install the pump in accordance with the National Electrical Codes. Use an with approved motor control that matches motor input full load amperes with a thermal overload relay or adjusted in accordance with the control instructions.
- Select the piping that fits to the flow capacity of the pump. Inappropriate piping (too large or too small) can result in excessive noise and vibration during the pump's operation.
- Make sure the check valve of the pipeline operate normally and check if the flow capacity is correct. Air might be gathering in the check valve if the pump is operating without discharging the water. The air has to be released if an air pocket is found at the check valve.

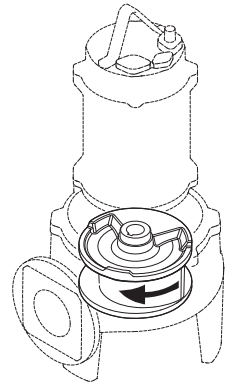

6 Maintenance

Only qualified mechanics with proper tools and knowledge should attempt to service this pump.

6.1 General Instruction

CAUTION

- Warning about hazards that will or can cause minor personal injury, product damage, or property damage.
- It must be very careful when disassembling and replacing new O-ring to assemble the motor and mechanical seal chamber. Improper assembly may impair the water resistance and cause motor burn by leakage, and it will void the warranty.

WARNING

- Hazardous voltage can shock, burns, or kill. Disconnect the electrical power before attempting any service or work on pump.

6.2 Maintenance Schedule routine

Daily	1.Operating Current: within range of current rating. 2.Operating Voltage: within a safe range. ($\pm 10\%$ of rated voltage) 3.Check the output flow rate for its normal value.
Monthly	Check the insulation, if it is lower than 20M Ω (with a 500V megger),maintenance is recommended. Replace a new motor immediately when insulation is lower than 1M Ω .
Annually	Inspect lubricant : Pumps should be checked every 6000 hours or 12 months (whichever comes first). [Remarks] Loosen the oil plug screw and check the color of the lubricant. If the lubricant looks unclear, please change the mechanical seal and the lubricant immediately. Apply adhesive before re-securing the oil plug screw to strengthen the screw against leakage. Oil specifications: VG32 or equivalent.
Every 2 to 5 years	1.Strongly recommended to overhaul or inspect the pump regularly even if it is still operating. This maintaining procedure can extend the pump's operating lifecycle. 2.Please contact your authorized local dealers or HCP for such service.

7

Troubleshooting

WARNING

Hazardous voltage can shock, burns, or kill. Disconnect the electrical power before attempting any service or repair work on pump.

SYMPTOM	POSSIBLE CAUSE	RECOMMENDED SOLUTION
Pump Not Operating	Power failure	Check power and correct connection.
	Defective cable	Replace power cable.
	Impeller clogged	Remove the foreign objects from impeller or casing.
	Bad Motor Protector	Replace new motor protector.
	The motor burn out	Rewind or Replace new motor.
	Float switch defective	Replace new float switch.
	Bad Control Panel	Repair or replaced.
Pump stop during operation	Impeller Jammed	Remove the foreign objects from impeller or casing.
	Abnormal voltage	Check the power and make sure it corresponds to the nameplate.
	The motor protector tripped	Make sure liquid temperature is below 40°C pump is complete submerged.
Pump not reaching design Flow rate	Incorrect rotation	Reverse two of three leads on a three phase motor.
	Worn and damaged impeller or cavitation	Replace new impeller.
	The block of strainer	Remove the foreign objects from impeller or casing.
	Objects inside the pump or the impeller	Remove the foreign objects from impeller or casing.
	Valves and pipe plugged	Remove plugged objects or replace new valves or pipes.
	System head excessive	Consult dealer.
	Cavitations	Reposition liquid level control.
Electric Leakage Circuit Breaker Activated	Power cable damaged	Replace new cable.
	Wet cable terminal	Reconnect after drying out.
	Worn mechanical seal cause water enter	Replace new mechanical seals and oil seal.
	The motor burns	Replace new motor.
Abnormal High Amperage	Abnormal voltage	Check the power and make sure it corresponds to the nameplate.
	Incorrect rotation	Reverse two of three leads on a three-phase motor.
	High viscosity liquid	More liquid needs to be added to the pump fluid to decrease its viscosity.
	Objects inside the pump or the impeller	Remove the foreign objects from impeller or casing.
	Defective bearings	Replace new bearing.

8

Parts Drawing

Single-Phase

8.1 1phase A-05B

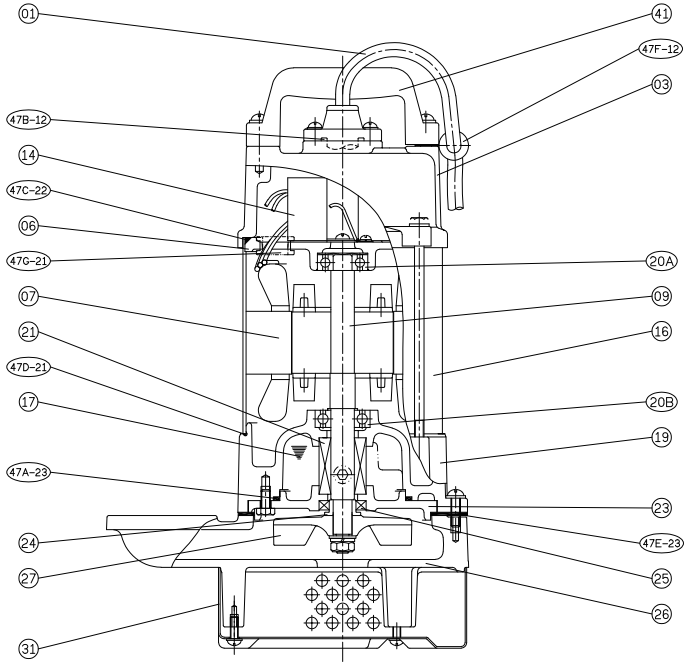

NO.	Part name	Material	QTY	NO.	Part name	Material	QTY
01	Cable		1	25	Oil Seal	NBR	1
03	Upper Cover	FC200	1	26	Casing	FC200	1
06	Bracket	FC200	1	27	Impeller	PA+G50	1
07	Stator (With Thermal Protector)		1	31	Strainer	SUS304	1
09	Shaft End	SUS410	1	41	Handle	ABS	1
14	Capacitor		1	47	Gasket Kit		
16	Motor Frame	SUS304	1				
17	Lubricant						
19	Bearing Bracket	FC200	1				
20A	Bearing		1				
20B	Bearing		1				
21	M. Seal	CA/CE & SiC/SiC	1				
23	M. Seal Bracket	FC200	1				
24	Oil Seal Bush	SUS304L	1				

8

Parts Drawing

Single-Phase

8.2 1phase A-05L

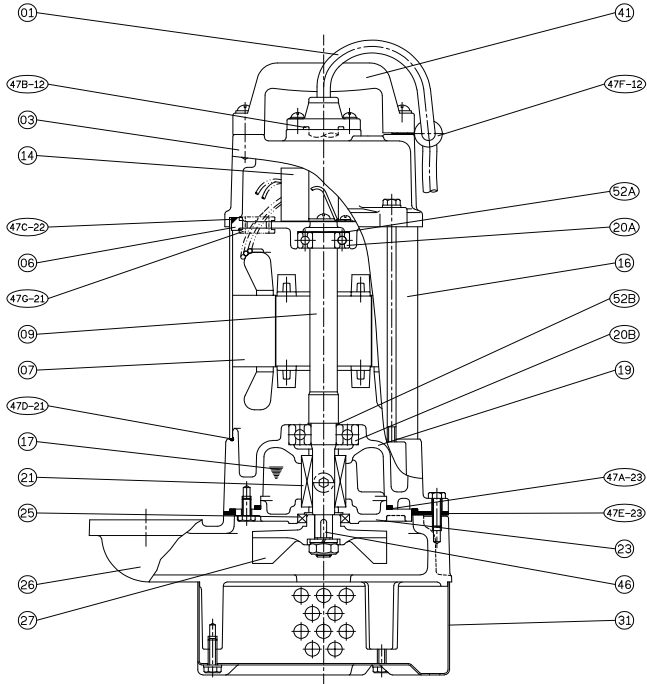

NO.	Part name	Material	QTY	NO.	Part name	Material	QTY
01	Cable		1	26	Casing	FC200	1
03	Upper Cover	FC200	1	27	Impeller	FC200	1
06	Bracket	FC200	1	31	Strainer	SUS304	1
07	Stator (With Thermal Protector)		1	41	Handle	ABS	1
09	Shaft End	SUS410	1	46	Impeller Key	SUS304	1
14	Capacitor		1	47	Gasket Kit		
16	Motor Frame	SUS304	1				
17	Lubricant						
19	Bearing Bracket	FC200	1				
20A	Bearing		1				
20B	Bearing		1				
21	M. Seal	CA/CE & SiC/SiC	1				
23	M. Seal Bracket	FC200	1				
25	Oil Seal	NBR	1				

8

Parts Drawing

Single-Phase

8.3 1phase A-21

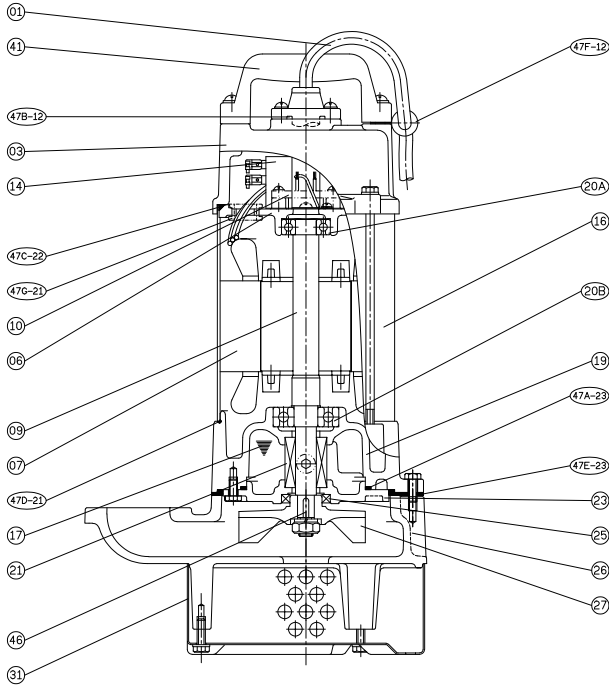

NO.	Part name	Material	QTY	NO.	Part name	Material	QTY
01	Cable		1	25	Oil Seal	NBR	1
03	Upper Cover	FC200	1	26	Casing	FC200	1
06	Bracket	FC200	1	27	Impeller	FC200	1
07	Stator		1	31	Strainer	SUS304	1
09	Shaft End	SUS410	1	41	Handle	ABS	1
10	Auto-cut Protector		1	46	Impeller Key	SUS304	1
14	Capacitor		1	47	Gasket Kit		
16	Motor Frame	SUS304	1				
17	Lubricant						
19	Bearing Bracket	FC200	1				
20A	Bearing		1				
20B	Bearing		1				
21	M. Seal	CA/CE & SiC/SiC	1				
23	M. Seal Bracket	FC200	1				

8

Parts Drawing

Single-Phase

8.4 1phase A-31

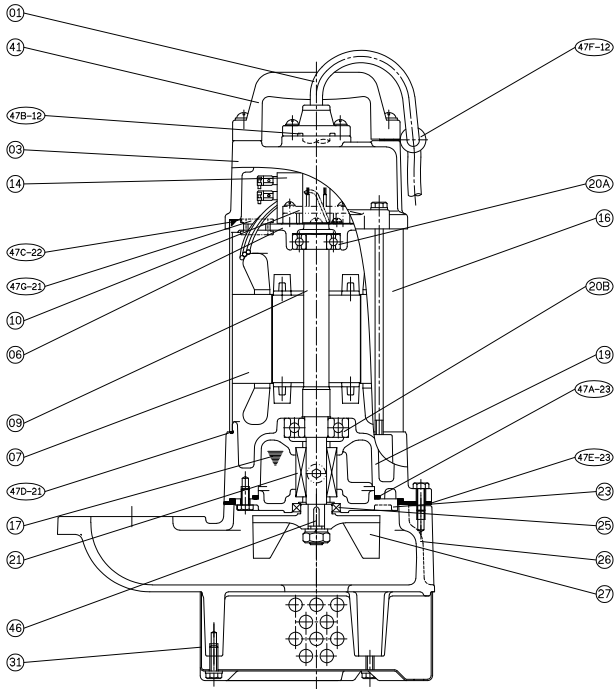

NO.	Part name	Material	QTY	NO.	Part name	Material	QTY
01	Cable		1	25	Oil Seal	NBR	1
03	Upper Cover	FC200	1	26	Casing	FC200	1
06	Bracket	FC200	1	27	Impeller	FC200	1
07	Stator		1	31	Strainer	SUS304	1
09	Shaft End	SUS410	1	41	Handle	ABS	1
10	Auto-cut Protector		1	46	Impeller Key	SUS304	1
14	Capacitor		1	47	Gasket Kit		
16	Motor Frame	SUS304	1				
17	Lubricant						
19	Bearing Bracket	FC200	1				
20A	Bearing		1				
20B	Bearing		1				
21	M. Seal	CA/CE & SIC/SIC	1				
23	M. Seal Bracket	FC200	1				

8

Parts Drawing

Single-Phase

8.5 1phase A-23H/33H

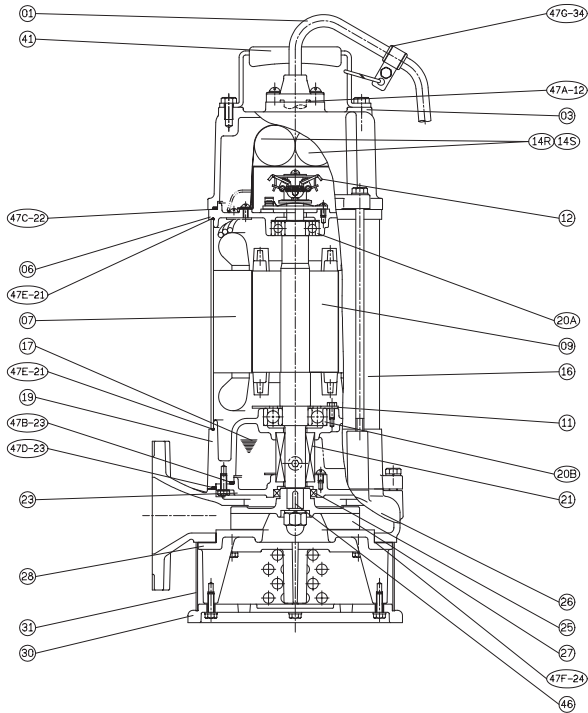

NO.	Part name	Material	QTY	NO.	Part name	Material	QTY
01	Cable		1	21	M. Seal	CA/CE & SIC/SIC	1
03	Upper Cover	FC200	1	23	M. Seal Bracket	FC200	1
06	Bracket	FC200	1	25	Oil Seal	NBR	1
07	Stator		1	26	Casing	FC200	1
09	Shaft End	SUS403	1	27	Impeller	FC200	1
11	Bearing Fixer	SPCC	1	28	Casing Cover	FC200	1
12	Centrifugal Switch		1	30	Footing	FC200	1
14R	Capacitor		1	31	Strainer	SUS304	1
14S	Start Capacitor		1	41	Handle	SUS304	1
16	Motor Frame	SUS304	1	46	Impeller Key	SUS304	1
17	Lubricant			47	Gasket Kit		
19	Bearing Bracket	FC200	1				
20A	Bearing		1				
20B	Bearing		1				

8

Parts Drawing

Three-Phase

8.6 3phase A-05B

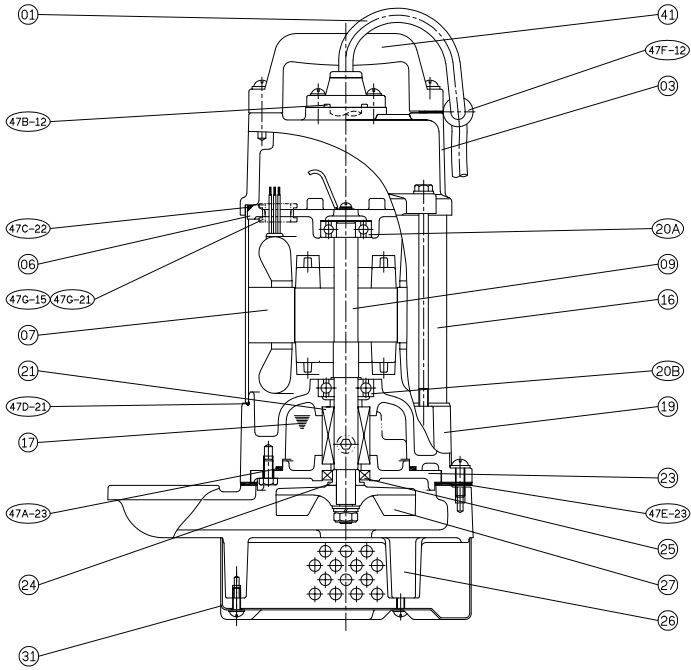

NO.	Part name	Material	QTY	NO.	Part name	Material	QTY
01	Cable		1	26	Casing	FC200	1
03	Upper Cover	FC200	1	27	Impeller	FC200	1
06	Bracket	FC200	1	31	Strainer	SUS304	1
07	Stator		1	41	Handle	ABS	1
09	Shaft End	SUS410	1	47	Gasket Kit		
16	Motor Frame	SUS304	1				
17	Lubricant						
19	Bearing Bracket	FC200	1				
20A	Bearing		1				
20B	Bearing		1				
21	M. Seal	CA/CE & SiC/SiC	1				
23	M. Seal Bracket	FC200	1				
24	Oil Seal Bush	SUS304L	1				
25	Oil Seal	NBR	1				

8

Parts Drawing

Three-Phase

8.7 3phase A-05L/21

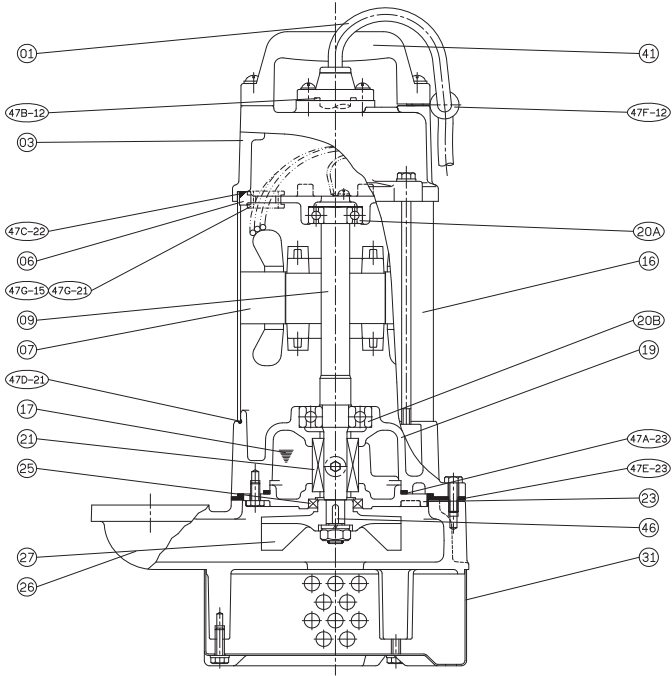

NO.	Part name	Material	QTY	NO.	Part name	Material	QTY
01	Cable		1	27	Impeller	FC200	1
03	Upper Cover	FC200	1	31	Strainer	SUS304	1
06	Bracket	FC200	1	41	Handle	ABS	1
07	Stator		1	46	Impeller Key	SUS304	1
09	Shaft End	SUS410	1	47	Gasket Kit		
16	Motor Frame	SUS304	1				
17	Lubricant						
19	Bearing Bracket	FC200	1				
20A	Bearing		1				
20B	Bearing		1				
21	M. Seal	CA/CE & SiC/SiC	1				
23	M. Seal Bracket	FC200	1				
25	Oil Seal	NBR	1				
26	Casing	FC200	1				

8

Parts Drawing

Three-Phase

8.8 3phase A-31

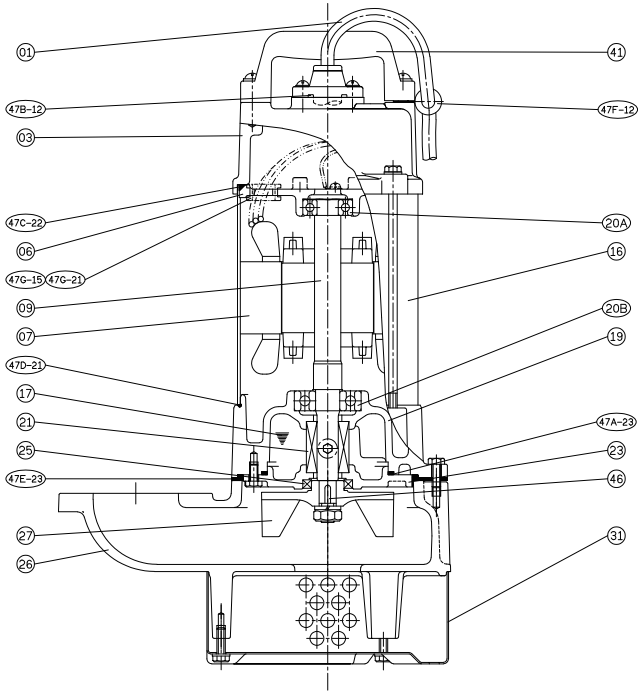

NO.	Part name	Material	QTY	NO.	Part name	Material	QTY
01	Cable		1	27	Impeller	FC200	1
03	Upper Cover	FC200	1	31	Strainer	SUS304	1
06	Bracket	FC200	1	41	Handle	ABS	1
07	Stator		1	46	Impeller Key	SUS304	1
09	Shaft End	SUS410	1	47	Gasket Kit		
16	Motor Frame	SUS304	1				
17	Lubricant						
19	Bearing Bracket	FC200	1				
20A	Bearing		1				
20B	Bearing		1				
21	M. Seal	CA/CE & SiC/SiC	1				
23	M. Seal Bracket	FC200	1				
25	Oil Seal	NBR	1				
26	Casing	FC200	1				

9 Electrical Wiring

Single-phase 110/115/120v & 208/230/240v

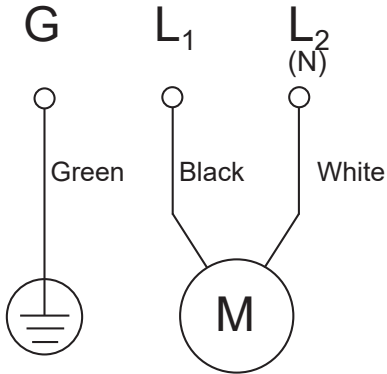

COLORS OF THE CABLE	
	SJOW
L1	Black
L2 (N)	White
G	Green

(N), Neutral for 110/115/120V

Three-phase 208/230/240v & 440/460/480v & 575/600v

An electric current must be flowing in a clockwise direction

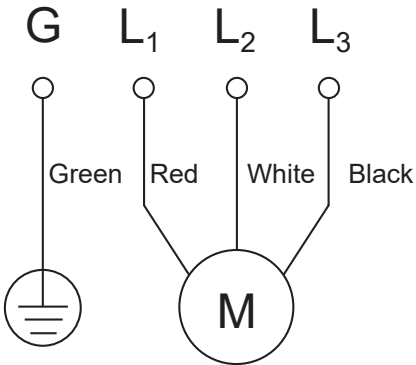

COLORS OF THE CABLE	
	SOW SOOW
L1	Red
L2	White
L3	Black
G	Green

Limited Warranty

1. HCP PUMPS warrants to the original Purchaser only that the Pump/Product ("Pump") will be free of defects in workmanship and material for a period of twelve (12) months from the date of installation or fifteen (15) months from the date of shipment by HCP PUMPS, whichever comes first.
2. This warranty is only available to the direct purchaser of HCP PUMPS products and does not extend to the customer of the purchaser. The warranty of the purchaser's customers is subject to the Purchaser's own warranty.
3. This warranty is valid for a period of fifteen months from the date of delivery shipment from HCP PUMPS.
4. HCP PUMPS warranty shall not apply to products that, in HCP PUMPS' sole judgment, have been subjected to the following circumstances.
 - a) Damages which is caused by negligence, abuse, or accident; or due to improper installation, transportation, or storage; or to unauthorized modification, tampering, or maintenance.
 - b) Damage caused by operating the product outside the HCP instruction manual, the technical, specifications or other published guidelines.
 - c) Damage which is caused by force majeure.
 - d) Damage which is caused by operation in excess of recommended pump performance maximums, other than normal application, operational failures caused by corrosion and rust, or other foreign substance in the system.
 - e) Damage which is caused by used to pump water at a temperature higher than recommended or water containing sand, iron ochre, lime, cement, gravel or other abrasive or corrosive materials, if the product was used to pump chemicals or hydrocarbons or hydrocarbon derivatives (oil, gasoline, solvents, etc.)
 - f) Consumable components, including but not limited to, mechanical seal, oil seal, impeller...etc, cetera, are not covered by the warranty, unless failure has occurred due to a defect in materials or workmanship.
5. This limited warranty covers only replacement for defective component(s). This limited warranty does not cover the relevant labor cost for component replacement and pump repair. The replacement component will be delivered with customer's next pending shipment.
6. In no event shall HCP PUMPS' cost responsibility exceeds the initial purchase pricing paid by the Purchaser for the Pump.
7. This limited warranty does not cover under warranty and is not liable for any loss of costs associated with any extra work caused by defect of the supplied product. Extra work includes but is including but not limited to diagnosing the cause of system problems; servicing HCP products; sorting, improving or re-delivery; personnel travel, transport, work, packaging or material costs; or installation/removal costs in production, in the warehouse or in the field, etc.



make future flow

A series of horizontal dotted lines for writing, spanning the width of the page.



make future flow

We reserve the right to alter specifications of product at any time without giving prior notice.

HCP PUMPS

Efficiency • Professionalism • Service • Commitment

Distributor:

HCP A-220201