

Instruction Manual

Dual Voltage Conversion Training (Pump Motor)

Purpose : To change the motor voltage configuration based on customer requirements by reconnecting the motor leads. Applicable Pump Model: AN-22-32

- From 208—240V → 380—480V, or
- From 380—480V → 208—240V

Step 1 — Verify Motor Configuration

Identify the motor type and current voltage configuration.

- Check the voltage on the nameplate.
- Confirm the motor leads: 12-leads
- Verify the pre-configured voltage.

This step is critical to determine the correct rewiring method.

Voltage
208 ~ 230v



(12 Leads Motor)

Step 2 — Open Upper Cover & Organize Wires

- Loosen the long screws and remove the upper cover.
- Refer to the wiring diagram for the target voltage.
- Identify and organize all motor leads.

Typical lead labels:

- U1, U2
- V1, V2
- W1, W2
- X1, X2
- Y1, Y2
- Z1, Z2

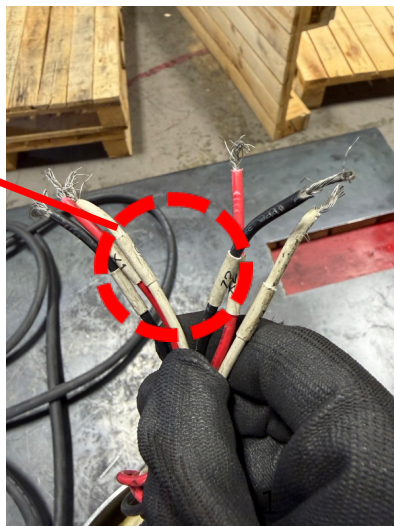

Instruction Manual

Dual Voltage Conversion Training (Pump Motor)

Step 3 — Perform Wiring Connections

- Connect wires according to the appropriate wiring diagram:
 - 208—240V configuration
 - 380—480V configuration
- Insert wires into closed-end connectors.
- Use a crimping tool to securely crimp the connectors.
- Perform a pull test to ensure all connections are tight and secure.



HCP HCP PUMP

WIRING DIAGRAM
MODEL : STATOR 12L Y CONNECTION 30
 No.: L1263BXX (12Leads 3Ph CN Y 380-480v)

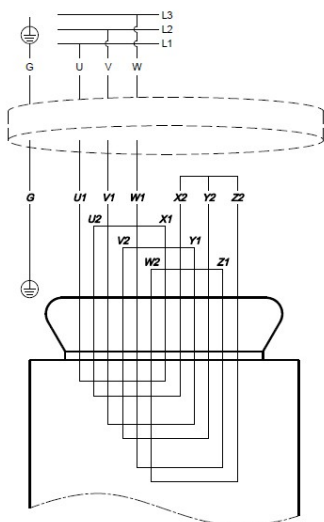

COLORS OF THE STATOR LEADS

U1/U2/X1/X2	Red
V1/V2/Y1/Y2	White
W1/W2/Z1/Z2	Black

COLORS OF THE CABLE

	VCT	H0TRN-F	SOW	S00W
U	Red	Brown	Red	
V	White	Black	White	
W	Black	Grey	Black	
G	Green	YellowGreen	Green	

CN : Y (380-480V) wiring diagram

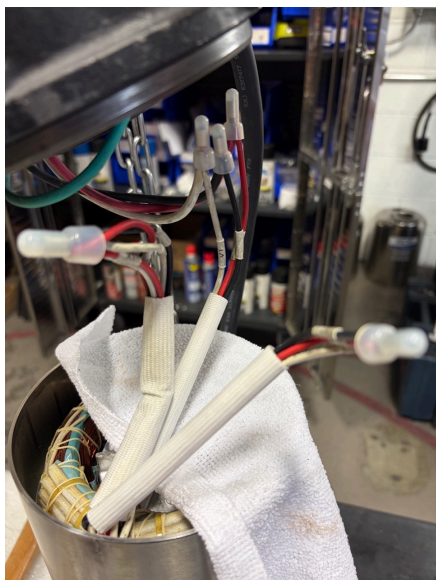

CN : Y (380-480V) configuration

HCP PUMP

WIRING DIAGRAM No1
MODEL I STATOR 12L 2Y CONNECTION 36
 No.: L1263AXX (12Leads 3Ph CN 2Y 208-240v)

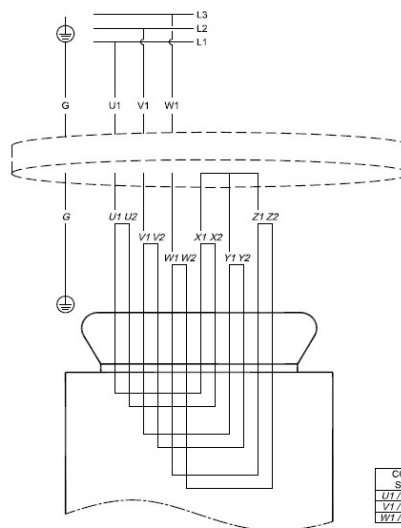

COLORS OF THE STATOR LEADS

U1/U2/X1/X2	Red
V1/V2/Y1/Y2	White
W1/W2/Z1/Z2	Black

COLORS OF THE CABLE

	VCT	H0TRN-F	SOW	S00W
U	Red	Brown	Red	
V	White	Black	White	
W	Black	Grey	Black	
G	Green	YellowGreen	Green	

CN : 2Y (208-240V) wiring diagram

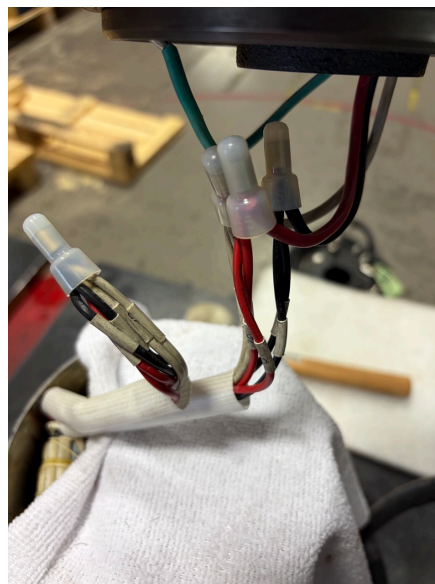

CN : 2Y (208-240V) configuration

Instruction Manual

Dual Voltage Conversion Training (Pump Motor)

Additional Note:

- If the exposed conductor is too short:
 - Use a wire stripper to remove additional insulation.
 - Ensure sufficient conductor length for proper connection.



wire stripper:

Strip insulation carefully without damaging the conductor.

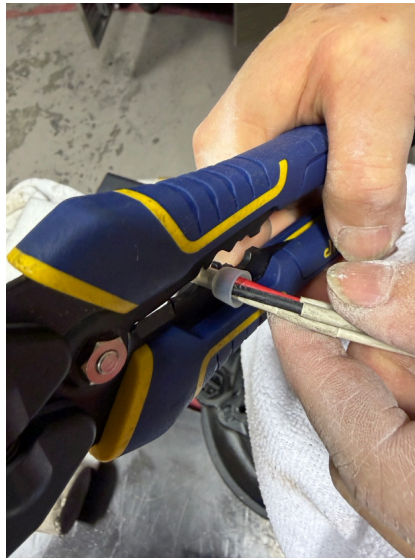

Wire Crimper:

Insert the wires fully into the closed-end connector before crimping.



Wire Crimper:

First apply a point crimp for positioning, then fully crimp the connector using the flat section.

Step 4 — Apply Grease to Wave Washer

Before reinstalling the upper cover:

- Apply a small amount of lubricating grease (3 points) to the wave washer.
- Ensure the wave washer is lightly adhered to the upper cover.

This helps keep the wave washer in position during assembly.



Hold the wave washer in place during assembly

Instruction Manual

Dual Voltage Conversion Training (Pump Motor)

Step 5 — Reinstall Upper Cover

- Carefully fold and arrange the wires inside the upper cover.
- Ensure wires are not pinched or damaged when closing the cover.
- Inspect the O-ring:
 - Ensure it is clean, intact, and properly seated.

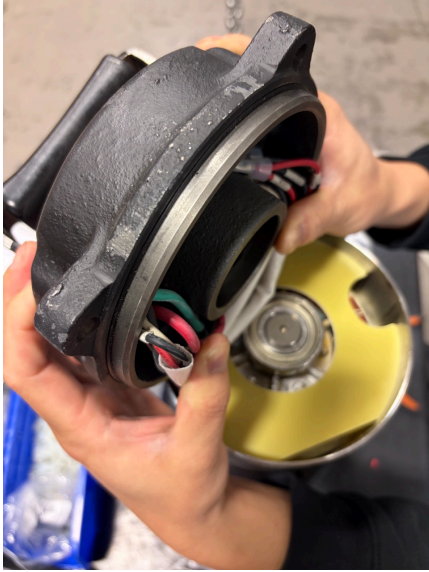

Step 6 — Align & Tighten Screws

- Align the first long screw with the weld seam on the pump as a reference point.
- Install the remaining screws in a cross (diagonal) pattern.
- Use a torque wrench to tighten all screws to the specified torque value.

This ensure the proper sealing and even presure distrubution



Align all bolts with the weld seam.



Tighten screws in a cross (diagonal) pattern.

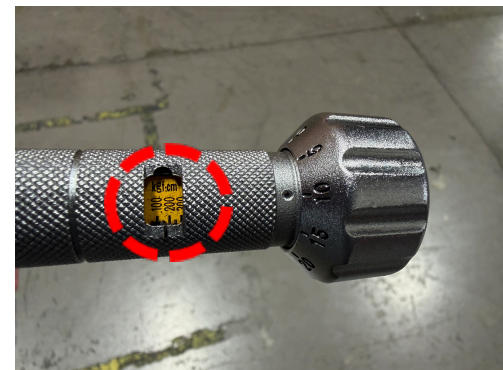

Set the torque according to the pump model.

Torque value : 160 kgf . cm

Additional Note:

Applicable Pump Models for 160 kgf . cm Torque

The following pump models share the same torque specification of 160 kgf . cm and can use this procedure.

This document applies to all models listed below with the same motor configuration.

Pump Model	Torque (kgf . cm)
AN-22	160
AN-23	160
AN-32	160
AN-33	160
AN-43	160
AN-35	160
FN-22	160
FN-23	160
FN-32	160
FN-33	160
FN-35	160
80SF 21.5	160
80SF 22.2	160
80SA21.5	160
80SA22.2	160